

Maintenance Manual
And
Instruction Book
For
MOTOR CYCLE (SOLO)
500 c.c. s.v.

BSA

Model M20



INDEX – GENERAL

	Pages		Pages
Brakes	28	Front Forks	23
Carburetter	10	Gearbox and Gearchange	25
Clutch	21	Hubs	27
Charging System	36	Ignition System	32
Electrical Wiring System	30-31	Lighting and Accessories	42
Engine Adjustments	8	Lubrication System	3
Engine – Complete dismantling	12	Lubrication Chart	4-5
Engine – Decarbonising	11	Steering Head	28
Engine – re-assembly	16	Transmission	20
Engine – removal from frame	12	Useful Data	2

INDEX – DETAILS

	Pages		Pages
BRAKES		Ignition System - continued	
Adjustment – Relining	28	Slipping clutch – sparking plug - Suppressor - immobiliser	33
CARBURETTER		Re-assembling and testing slipping clutch	35
Mixture – Needle position – Pilot adjustment – Throttle stop.	10	Lighting and Accessories	
ENGINE ADJUSTMENTS		Headlamp – Tail lamp – Cables - Lighting switch	42
Oil-pressure valves – Exhaust valve lifter	8	Horn	43
Tappets – Ignition timing	8-9	Wiring diagrams	30-31
ENGINE DISMANTLING		FRONT FORKS	
Cylinder head – Cylinder barrel – Valves	6-7	Adjustment	28
Valve grinding – Valve guides, removal and replacement	11	Dismantling – fitting new spring – re-assembly	29
Piston and Rings – Checking ring gap – removing engine from frame	12	GEARBOX	
Removing Magdyno pinion	13	Removal – dismantling	23
Oil pump, removal and dismantling – “Splitting” crankcase – removing Bearings	14	Dismantling Gearchange – Re-assembling Gearbox	24
Removing cam spindles – dismantling flywheels – reboring cylinder - fitting new cylinder lining.	15	Re-assembling gearchange	25
ENGINE RE-ASSEMBLY		Replacing gearbox	26
Flywheel assembly and alignment	16	HUBS	
Replacing oil pump – tappets – replacing bearings – re-assembling crankcase - Replacing timing gears & magdyno	17	Rear – adjustment – dismantling and Re-assembly	27
Replacing piston – cylinder barrel - timing Cover – cylinder head – exhaust valve lifter – refitting engine in frame.	18	Front	27-28
ELECTRICAL EQUIPMENT		LUBRICATION	
Charging System		Engine lubricating system	3
Dynamo		Lubrication chart	4
Testing – Removal and Replacement	36	Hubs – Brake cam spindles - Speedometer Drive – Filters – Rear chain – Dynamo - Gearbox	5
Dismantling – Brushes - Commutator	37	Oil pump – removal – dismantling and Re-assembly	14
Field coil, testing and removing - Armature – Bearings	38	TRANSMISSION	
Re-assembly	39	Clutch – adjustment	20
Cut-out and Regulator	39	Clutch – dismantling	21
Cleaning contacts – setting regulator - Cut-out	40	Clutch – re-assembly	22
Ammeter – Removal and Replacement	41	Chaincase - removal	12
Battery – Care of	41	Chaincase - replacement	18
Ignition System		Chain adjustment	20
Magneto lubrication – adjustment – testing - Cleaning contact breaker – H.T. cable - Pick-up	32	Wheel alignment	21
Removal – dismantling – removing and testing armature	34	SHOCK ABSORBER – Adjustment	28
Re-assembly	35	STEERING HEAD	
		Adjustment	28
		Dismantling – re-assembly	29

USEFUL DATA

Engine bore	82 mm
Engine stroke M20	94 mm
Engine stroke M21	112 mm
Engine Capacity	496cc
Petrol tank capacity	3 gallons
Oil tank capacity	5 pints
Gearbox capacity	1 pint
Inlet tappet clearance (cold)	.010"
Exhaust tappet (cold)	.012"
Compression M20	4,9:1
Compression M21	5:1
Tyres	3.25/3.50-19
Tyre Pressure	22psi
Piston ring gap	.008 - .012"
Piston clearance Bottom of skirt	.0035 - .0055"
Piston Ring side clearance	.002" - .004"
Ignition timing	7/16" BTDC
Magneto point gap	.012"
Spark plug gap	.012 - .018"
Carburetter- Jet	170
Carburetter- Needle	2nd notch
Engine Sprocket	19 teeth
Clutch sprocket	43 teeth
Gearbox Sprocket	18 teeth
Rear Wheel Sprocket	42 teeth
Primary Chain	95 links
Gear Ratio- Top	5.3
Gear Ratio- 3rd	7.0
Gear Ratio- 2nd	10.9
Gear Ratio- 1st	15.8

THE LUBRICATION SYSTEM

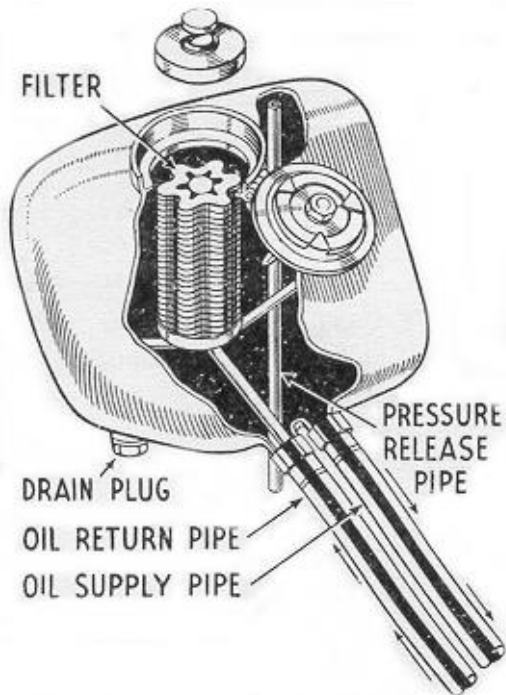
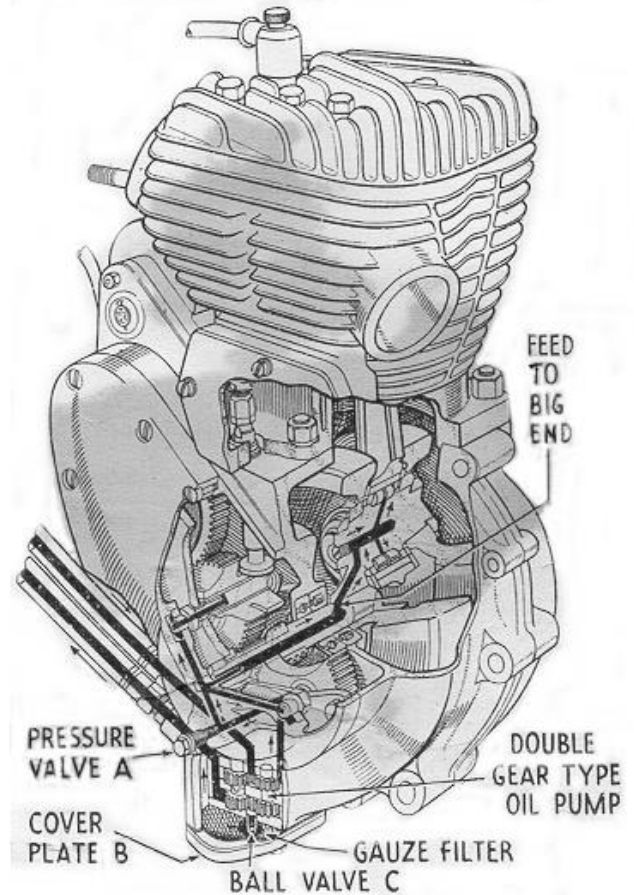

Fig. 1. Lubrication System

The engine lubrication system is of the dry sump type operated by a double gear pump, situated in the bottom of the crankcase on the right-hand side. All oilways are internal except for the supply and return pipes from the tank. The oil flows from the tank to the supply pump (the top pair of gears) and thence past the pressure valve (A) to the two oilways feeding the cam spindles, and along the hollow mainshaft to the big end bearing. After lubricating the big end and circulating through the engine in the form of a mist, the oil drains down through a filter in the bottom of the crankcase, from which it is drawn by the return pump (lower pair of gears) past ball valve (C), and delivered up the return pipe to the tank, where it passes through a fine mesh filter into the tank itself.

Incorrect seating of the ball valve (A), will allow oil to transfer from the tank to the engine, whilst the machine is stationary. If the ball valve (C) should get stuck in its seating, there will be no return of oil to the tank. To check the oil circulation open the tank filler cap and remove filter cap whilst the engine is running. Oil should be seen issuing from the return pipe from the crankcase. The tank and crankcase should be drained every 2,000 miles and replenished with clean oil.

Any restriction in the pressure release pipe in the tank will cause an increase in pressure inside the oil tank, and will result in leakage of oil at the filler cap. This can be put right by inserting a length of flexible wire into the pipe at its lower end (just in front of the rear mudguard) and pushing the wire right up the pipe, thus clearing any obstruction.



To remove the oil tank filter for cleaning, release the tank filler cap, release the filter tap thus exposed, and lift filter out. The filter should be placed in a can large enough to cover it with petrol, and thoroughly washed. Before replacing make sure that it is quite dry of petrol.

The pump filter can be withdrawn after removing the cover plate (B) and should be thoroughly washed with petrol, dried and replaced.

NOTE. It is not advisable to remove the oil pump unless the pump is definitely faulty.

LUBRICATION

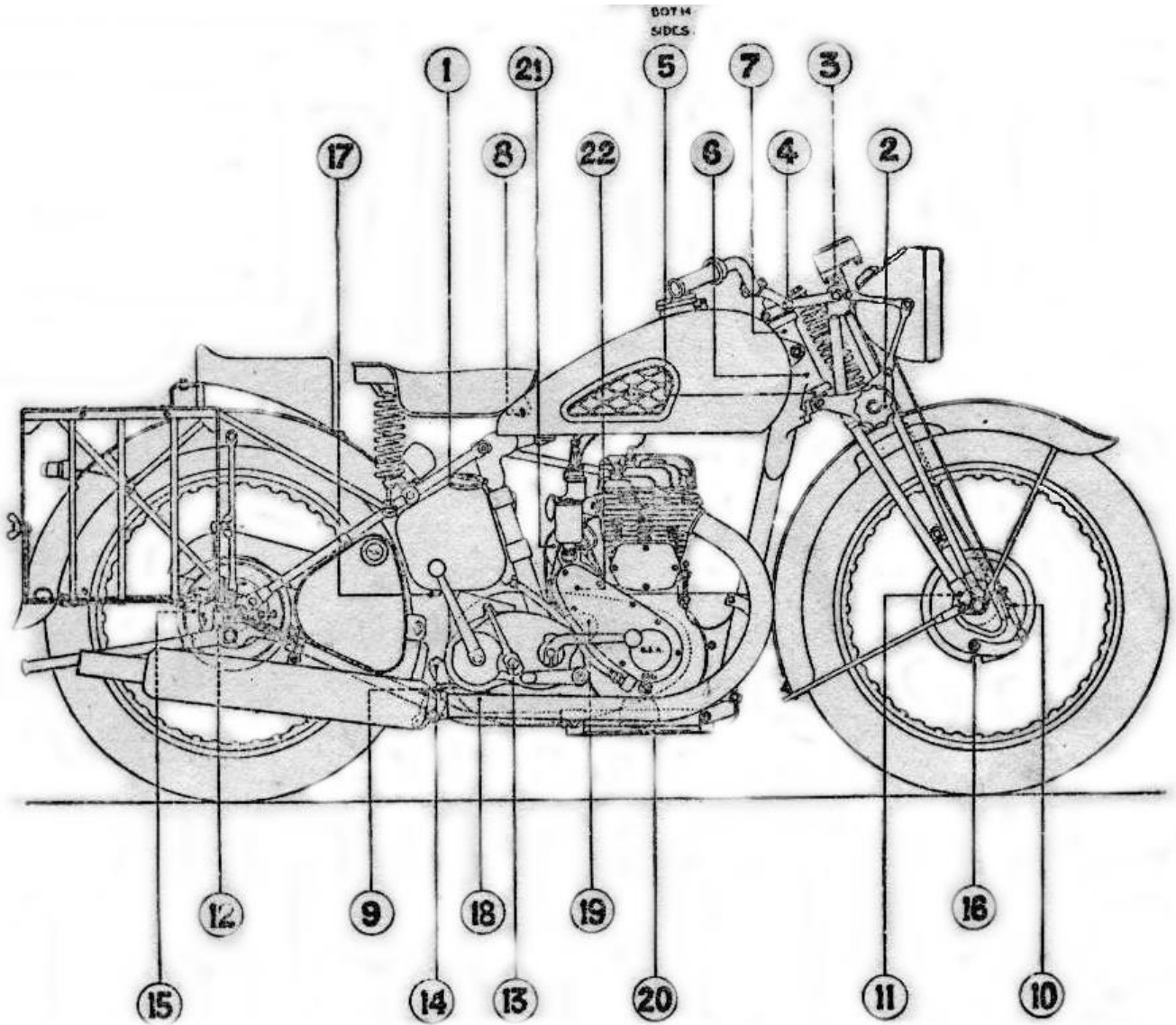

Fig 2. – Lubrication Chart

4 LUBRICATION CHART

No	PART	Lubricant	Type of Lubrication	Daily	250 Miles (Inclusive)	General
FRAME GROUP						
3	Front fork (top)	CG-1 (AL)	1 nipple		Grease Gun	
2	Front fork (centre)	CG-1 (AL)	1 nipple		Grease Gun	
4	Steering Stem (top)	CG-1 (AL)	1 nipple		Grease Gun	
5	Steering Stem (bottom)	CG-1 (AL)	2 nipple		Grease Gun	
7	Steering Head (top)	CG-1 (AL)	1 nipple		Grease Gun	
6	Steering Head (bottom)	CG-1 (AL)	1 nipple		Grease Gun	
8	Saddle nose pivot	CG-1 (AL)	1 nipple		Grease Gun	
11	Front wheel hub	CG-1 (AL)	Re pack		-	Re pack w shops every 5000 miles
12	Rear wheel hub	CG-1 (AL)	Re pack		-	Re pack w shops every 5000 miles
BRAKE GROUP						
9	Brake pedal	CG-1 (AL)	1 nipple		Grease Gun	
16	Brake cam (front)	CG-1 (AL)	1 nipple		Grease Gun	
15	Brake cam (rear)	CG-1 (AL)	1 nipple		Grease Gun	
	Bowden control wire	OE-30	Oil Can		Few Drops	
	Foot brake linkage	OE-30	Oil Can		Few Drops	
ENGINE GROUP						
1	Engine oil tank	OE50	5 pints	Replenish	Replenish	Drain & refill at 1000 miles (AO17)
19	Primary chain case	OE50	Reservoir	Replenish	Replenish	Drain & refill at 1000 miles (AO17)
1/20	Oil Filters	OE50				Wash in petrol every 2000 miles
IGNITION GROUP						
	Advance Retard Cable etc	OE30	Oil Can		Few drops	
	Contact breaker tappet	OE30	Oil Can		One drop	
22	Contact breaker cam	CG-1 (AL)	Hand smear		Slight smear	
	Generator (drive end)	WB-2	Re pack			Re pack w shops
21	Generator (commutator end)	OE30	Oil Can		Few drops	
FUEL GROUP						
	Air cleaner		N/A			
	Carburettor control cables	OE30	Oil Can		Few drops	
	Throttle handle bar grip	OE30	Oil Can		Few drops	
TRANSMISSION GROUP						
10	Speedometer drive	CG-1 (AL)	1 nipple		Grease Gun	
	Speedometer cable	OE30	Oil can		Few drops	
14	Gear box	GO-90	1 pint		Replenish	Drain & refill each 6000 miles No 18
12	Clutch push rod	OE-50	Oil can		Few drops	
	Clutch bowden control wire	OE30	Oil can		Few drops	
	Clutch handle bar grip	OE30	Oil can		Few drops	
	Rear chain	OE30	Oil can		Few drops	Wash in paraffin and soak in oil OE-50 every 2000 miles. Workshops

THE ENGINE – EXPLODED VIEW

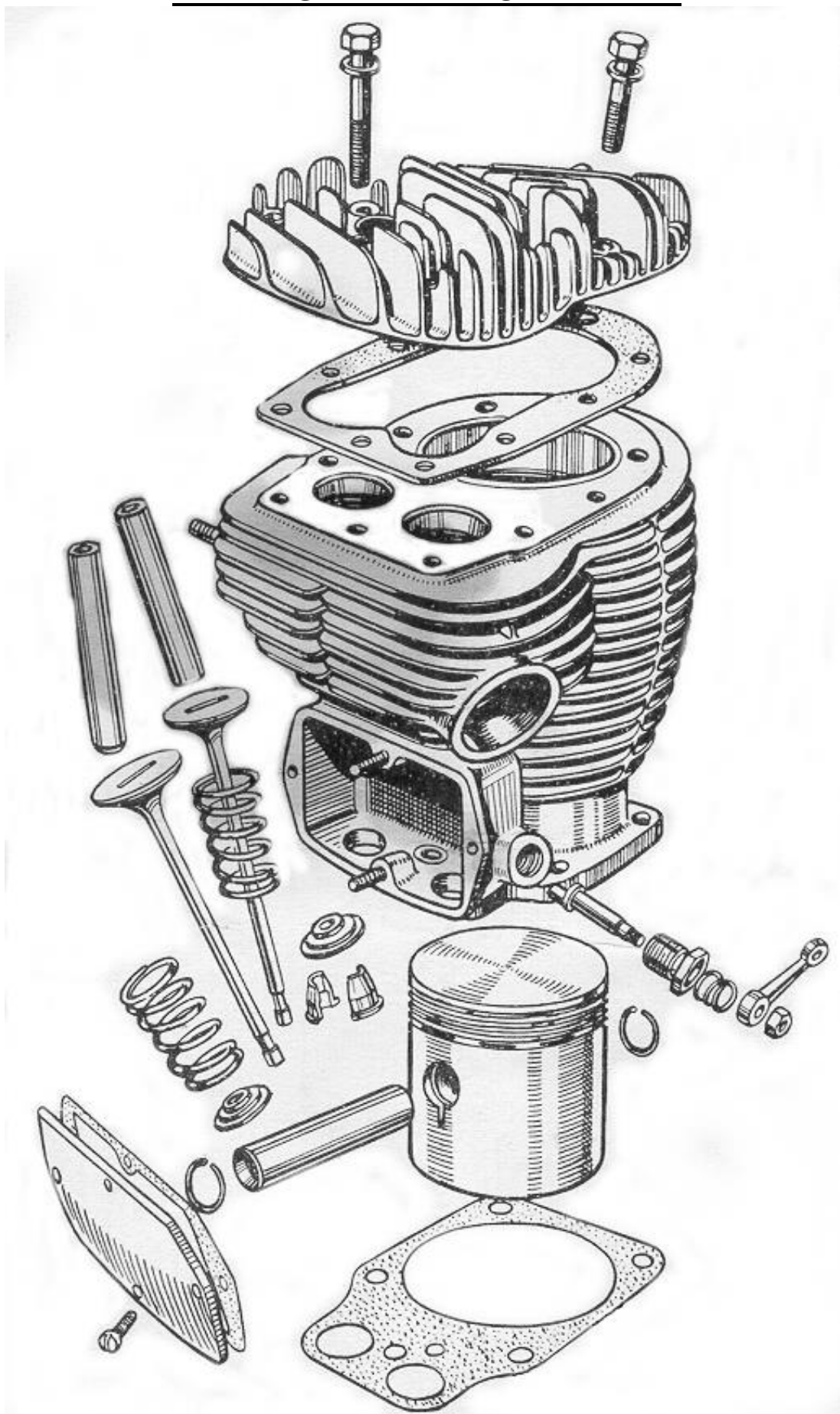

Fig. 3. Top half of engine (exploded view)

THE ENGINE – EXPLODED VIEW

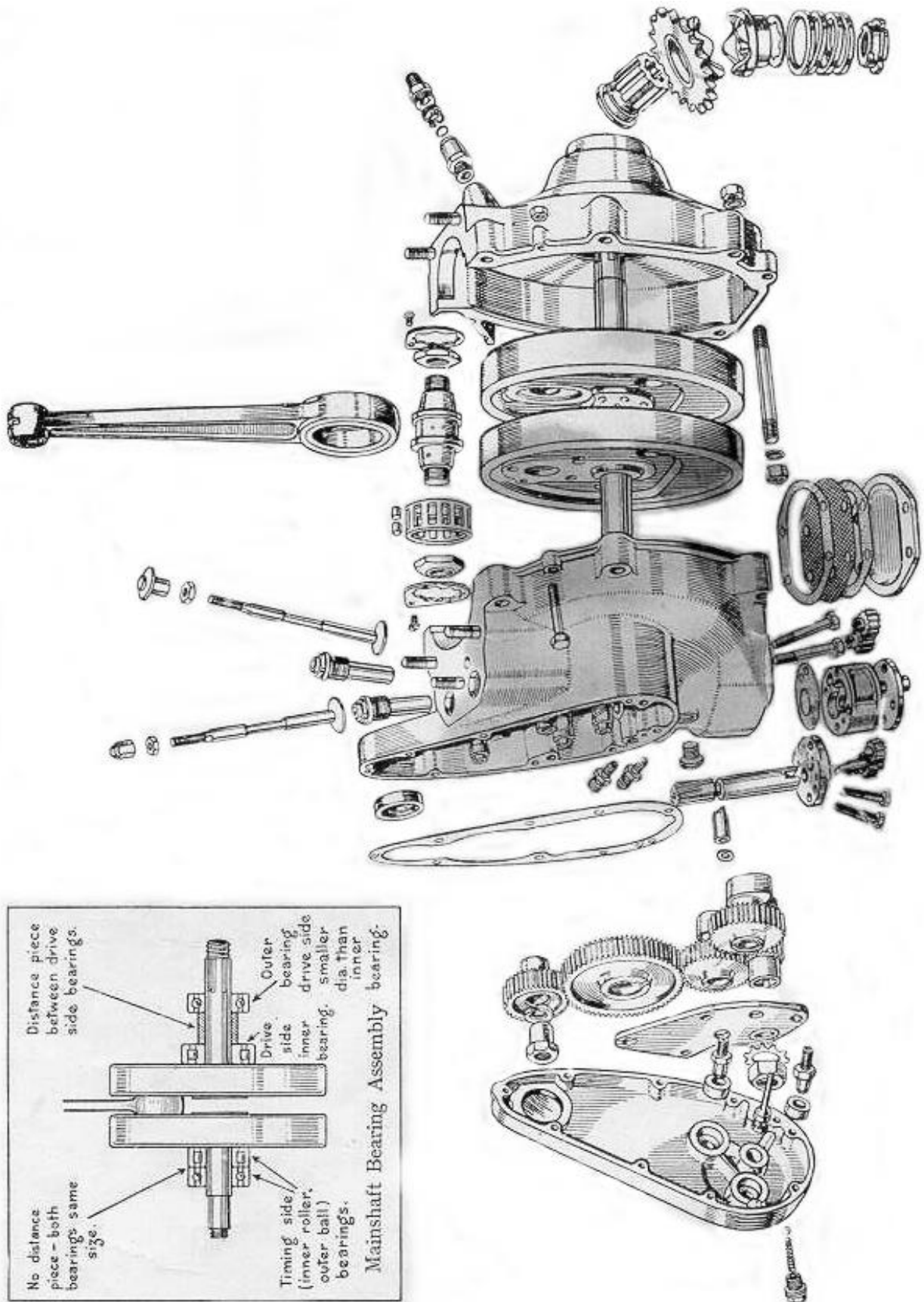

Fig.4. Crankcase half of engine (exploded view)

ENGINE ADJUSTMENTS

Which can be carried out without dismantling

OIL PRESSURE VALVES

As described under the heading "How the Lubrication System Works" on page 3 there are two ball valves incorporated in the lubrication system to prevent the transfer of oil from the tank to the crankcase.

The spring loaded valve is located in the delivery passage between the pump and the big-end, and lies behind the hexagon plug at the lowest point of the timing cover (see Fig. 5).

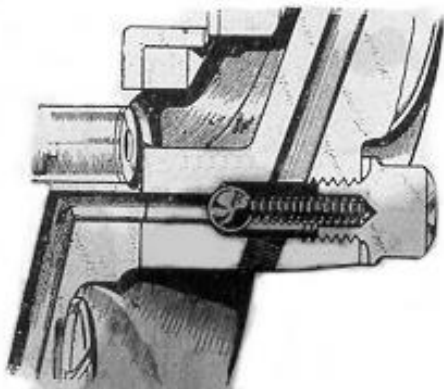

Fig. 5. Pressure valve in timing cover.

Should any foreign matter lodge between the ball and its seating oil will gradually transfer from the tank when the machine is left standing, and when the engine is started up there will be a heavy discharge of blue smoke from the exhaust.

To rectify, remove the plug, spring and ball. The simplest way of removing the ball is to hold the hand close to the orifice and gently turn the engine over, when the ball will be forced out.

Clean the ball and the seating, and if on replacing there is still doubt as to whether the ball is seating properly, insert a small punch against the ball and deal it a sharp tap with a light hammer. Finally replace the spring and plug.

The other ball valve is located between the return pump (Fig. 6), and apparent failure of the return pump may be due to this ball having stuck in its seating.

To rectify, remove the pump cover plate, insert a piece of wire into the valve orifice and lift the ball off its seating. Should the trouble keep recurring it may be necessary to fit a new base plate to the pump.

On no account remove the oil pump unless it is absolutely necessary.

EXHAUST VALVE LIFTER

The peg on the exhaust valve lifter inside the tappet chest must always be well clear of the collar on the exhaust tappet (see Fig. 7), otherwise the engine will be noisy and the tappet clearances seriously affected. Failure to check that there is clearance at this point may result in a badly burnt exhaust valve.

Adjustment is carried out by means of the cable adjuster at the side of the tappet chest.

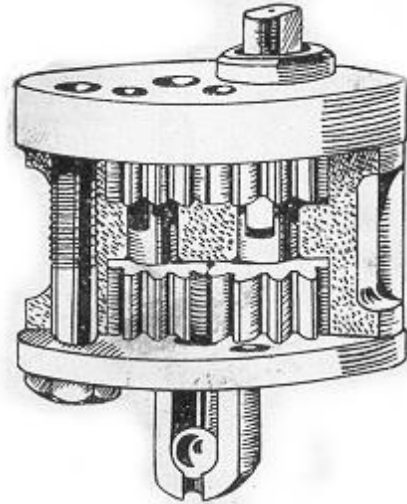

Fig. 6. Ball valve below return pump.

TAPPET ADJUSTMENT

Before any attempt is made to adjust tappet clearances, check that the exhaust valve lifter is correctly adjusted as explained in the previous paragraph.

To check and adjust tappet clearances, it is most essential, owing to the special design of the cam form (see Fig. 8), that the following procedure be adhered to.

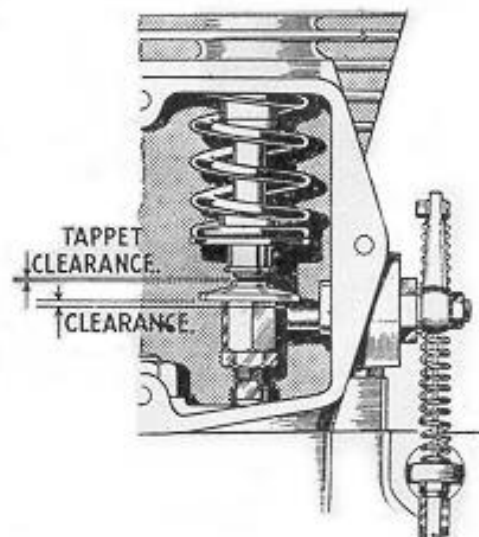

Fig. 7. Tappet and exhaust valve lifter.

Rotate engine forward until the inlet valve has just closed (until tappet is just free to rotate). Now adjust the exhaust tappet clearance to .012". Turn engine forward again until the exhaust tappet clearance is just taken up (but before valve actually starts to lift). Now adjust inlet tappet clearance to .010"

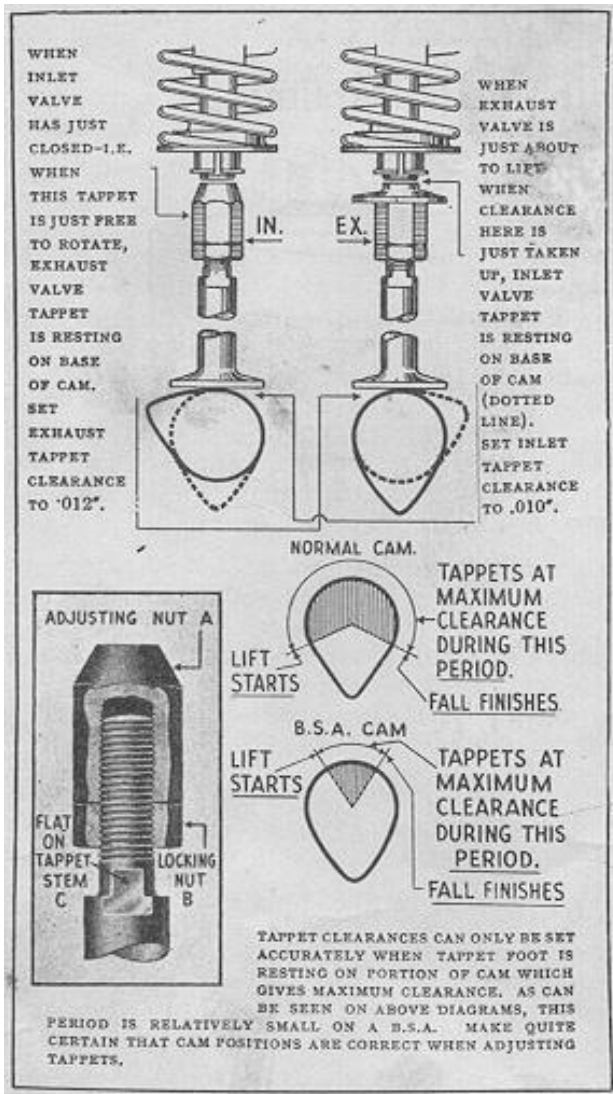

Fig. 8. Instructions for setting tappets

The actual adjustment is carried out by releasing the locknut (B) (Fig. 8), holding the tappet with a spanner on the flat (C), and screwing the tappet head (A) either up or down. When correct clearance is obtained, the locknut must be tightened against the tappet head. It is advisable, after locking up, to check clearance again, to make sure that the adjustment has not been affected. Tappet adjustment should always be carried out with the engine dead cold, and the clearances recommended above regarded as a minimum, especially in the case of the exhaust valve.

IGNITION TIMING

It is a rare occurrence for the magneto pinion to slacken off and disturb the ignition setting, and it is not advisable to interfere with the setting unless it is known to be at fault. It is however advisable to check over the timing after carrying out any adjustment to the magneto contact points, as a slight variation of the points tends to advance or retard the timing. (Opening the points advances timing, closing them retards timing). If the timing requires re-setting, first remove the timing cover, and in so doing take care not to

damage the small nozzle in the timing cover which feeds oil to the hollow crankshaft. With the cover removed, take off the nut locking the magneto pinion on its shaft, and with the aid of a magneto pinion extractor (Fig. 10) release the pinion on its taper. (Note that the pinion is held on its shaft by a plain taper only, and can only be released with safety by using the proper extractor.)

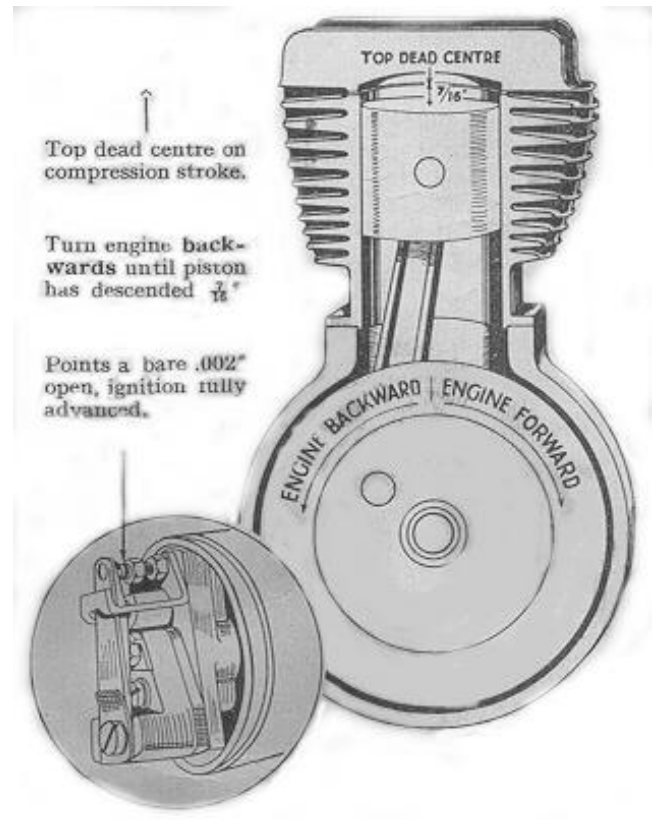

Fig. 9. Ignition timing,

Check that the fully open gap is correct to gauge (not exceeding .012"). To re-set timing, turn engine forward until piston reaches top dead centre on the compression stroke (see Fig. 9). Now turn engine until piston has descended $\frac{7}{16}$ ". With ignition control at full advance turn contact breaker in its direction of rotation until the points are just about to open (not more than .002" open). Lightly tighten the magneto pinion nut and carefully check figures and positions. Then tighten nut properly and re-check.

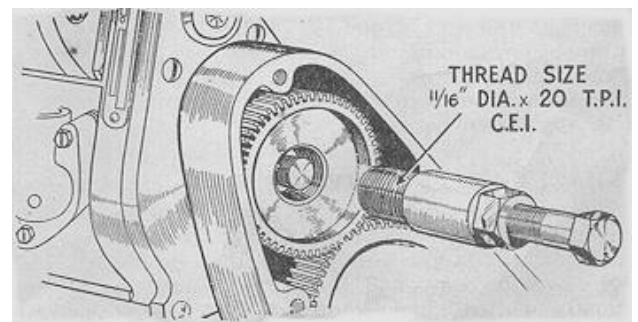

Fig. 10. Magneto pinion extractor.

CARBURETTOR

To maintain the efficiency of the carburettor it should be cleaned periodically by entirely dismantling it and washing each part in clean petrol.

Renew any worn parts, particularly in the needle valve if the head has a distinct ridge at the point of seating, throttle valve if excessive side play is present or taper needle and clip, if it is possible to rotate the needle freely in the clip. When re-assembling, make sure that the taper needle is refitted into the correct groove, is securely locked by the clip, and that it enters the central hole in the top of the jet block. Also verify that the needle valve enters the top of the float chamber easily, the mixing chamber flange joint is airtight, and the needle valve clip registers correctly in its groove. It will, of course, be necessary to reset pilot adjusting screw.

NEEDLE POSITION. Needle positions are counted from the top of the needle and the groove nearest the top is No. 1.

THROTTLE STOP. The position of the throttle valve is set by means of the throttle stop screw (See Fig 4), the throttle control being closed during this adjustment. Alternatively, if the screw is adjusted clear of the throttle valve, the engine will be shut off in the normal way by the control.

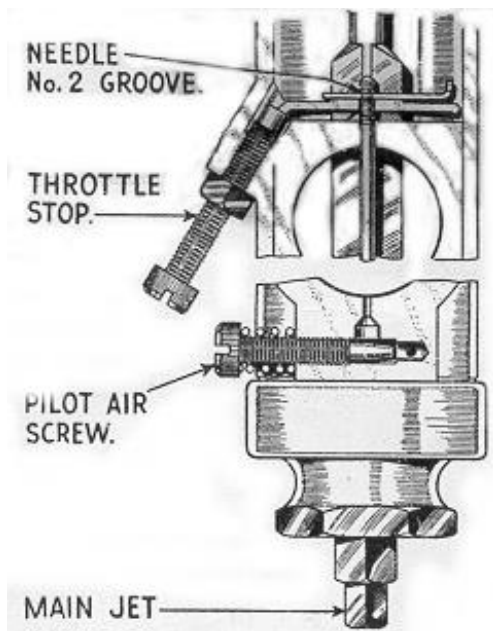

Fig. 11. Carburettor adjustments.

PILOT ADJUSTMENT. To weaken the slow running mixture, screw the pilot air adjuster outwards and to enrich the slow running mixture, screw the adjuster inwards.

Screw the air adjuster home in a clockwise direction. Warm up the engine, close the air lever and set the throttle about 1/8th open. Gently close the throttle when the mixture will prove too rich unless air leaks are present. Gradually unscrew the pilot air adjuster, when the engine speed will increase and must be

again reduced by gently closing the throttle, until by a combination of throttle positions and air adjustment, the desired idling is secured.

MIXTURE STRENGTHS. Weak mixture is indicated by difficult starting, a tendency for the engine to spit back through the carburettor (indicated by blue fumes from the air intake). The engine knocks, and runs hot with loss of power. The spark plug electrode shows indications of intense heat, and the mica insulation becomes white. If spitting back occurs, raise the needle in the throttle valve. Test by lowering the air valve gently. Engine revs will rise when the air valve is lowered slightly below the throttle valve.

Rich mixture indications are heavy "thumpy" running with emission of black smoke from the exhaust pipe. As the throttle is opened heavy blowback of fuel is observed from the carburettor air intake. If the engine speed does not increase progressively as the throttle is raised, lower the needle in the throttle valve.

The normal needle setting is with the clip in No. 2 groove.

SPARKING PLUG

The machine is supplied with a K.L.G. type F70 sparking plug, and is of a three-piece construction. After dismantling, the lower (taper) portion should be scraped clean of all carbon deposit.

Note: Earlier models are fitted with type L777 plug – a three-point plug with mica insulation. Where mica insulation is used, the mica must on no account be scraped, but cleaned with petrol and a rag. The inside of the body should be well scraped, and the earth point cleaned.

When re-assembling, verify that the internal washer is in place before inserting the electrode. Having tightened the gland nut, set the earth point to give a gap of 0.015" to 0.018". This may mean bending the earth point towards the centre electrode, or if the gap is too narrow, prising it outwards. The centre electrode must not be levered towards the earth point. The external washer should be replaced if it is broken or has been completely flattened.

SYMPTOMS OF MINOR PLUG TROUBLES.

Misfiring especially at high speeds and under heavy pulling at lower speeds, invariably indicates that the gap setting of the plus is too wide, whilst erratic slow running can be accounted for by too narrow a gap setting. An over rich mixture will result in trouble in the form of an excess deposit of soot on the internal insulation of the plus with consequent "shorting" inside the plug. A faulty high tension cable, or the magneto contact points being out of adjustment will also account for the plug misfiring.

ENGINE DISMANTLING for DECARBONISING

When decarbonising, it is not necessary or desirable to dismantle the cylinder barrel, unless it is suspected that the valves, pistons or its rings are the cause of some trouble. It is sufficient to remove the cylinder head and gasket thus exposing the piston and valves.

REMOVING CYLINDER HEAD

To detach cylinder head, disconnect sparking plug lead, remove steady strap and the 10 cylinder head bolts. Head can then be lifted off.

Rotate the engine until the piston is at the top of its stroke and scrape it with an old penknife, taking great care not to damage the piston crown. Then clean the cylinder head and replace, tightening the bolts in the order shown in Fig. 24.

If the valve seats are suspected of gas leakage, due to insufficient tappet clearances or other causes these should be remedied. It is possible to grind in the valves in position, but it is preferable to remove the barrel from the crankcase so that the work may be carried out on the bench, and at the same time the piston and rings inspected.

REMOVING CYLINDER BARREL

To remove cylinder barrel, first turn off petrol taps and detach carburetter. This can be tied to frame out of the way. Next, the exhaust pipe and silencer should be removed complete. The exhaust valve lifter should be unscrewed from the tappet chest until the eccentric peg on the lifter is clear of the tappet head. Uncouple the exhaust valve lifter by removing

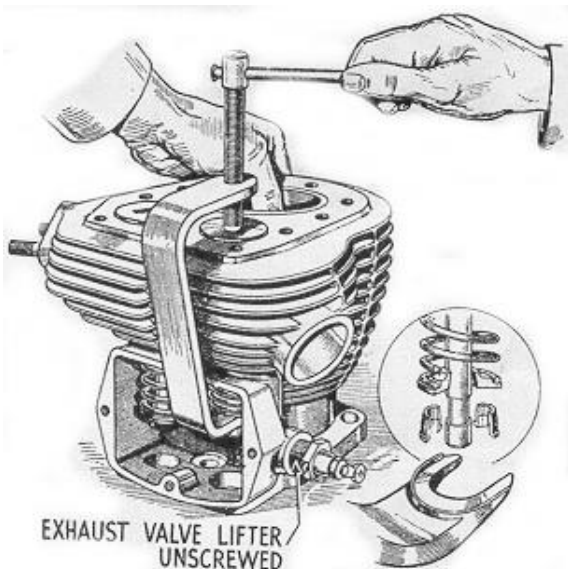

Fig. 12. B.S.A. Valve removing tool.

the pin at the lever end. Now remove the five cylinder base nuts (four outside and one inside tappet chest), and cylinder barrel can be lifted off.

When removing the cylinder barrel, the simplest way is to lift it up and tilt it forwards into the front angle of the frame. The piston should be steadied as it emerges from the barrel to prevent possible damage. Cover the crankcase mouth with rag to prevent dust and grit falling in.

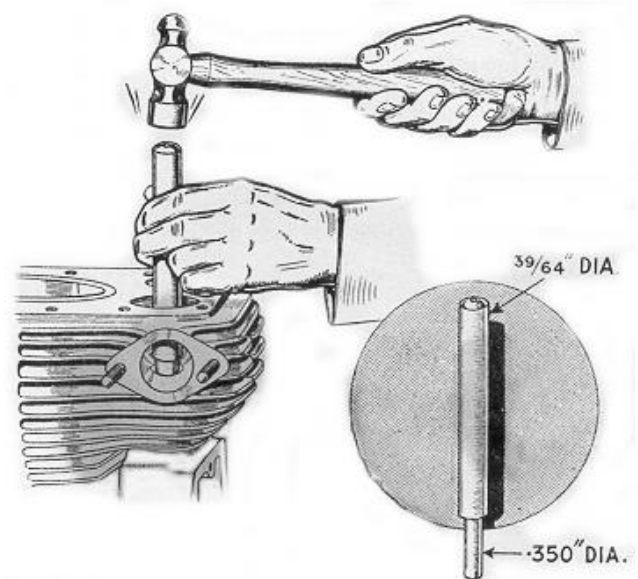

Fig. 13. Inserting valve guides

REMOVING THE VALVES

To remove the valves an extractor as shown in Fig. 12 may be used. If the proper extractor is not available, the valves may be removed by laying the cylinder barrel on a bench (valve heads downwards) and compressing the valve springs with the aid of a piece of tube (suitably slotted), while an assistant removes the cotters. Clean all carbon from the ports and check valve guides for wear.

FITTING NEW VALVE GUIDES

If new guides are to be fitted, the old ones may be extracted (from below) by means of a simple punch (consisting of a bar of steel of not more than 5/8" diameter - Fig. 13). The new guides can be driven in from the top with the same punch and it is important that the dimensions from the top of the guide to the cylinder head joint (as shown in Fig. 14) should be carefully observed. After the new guides have been inserted, the valve seats should be re-cut with a pilot cutter to ensure concentricity of seats and stems (see Fig. 14). Note that the exhaust valve guide only has its upper end counterbored.

GRINDING IN VALVES

If the old valves are to be retained, they should only be ground in if the seating shows slight pitting. If badly pitted, they should be refaced, otherwise excessive grinding

will wear away the seat in the cylinder barrel and cause the valve to become pocketed. Take great

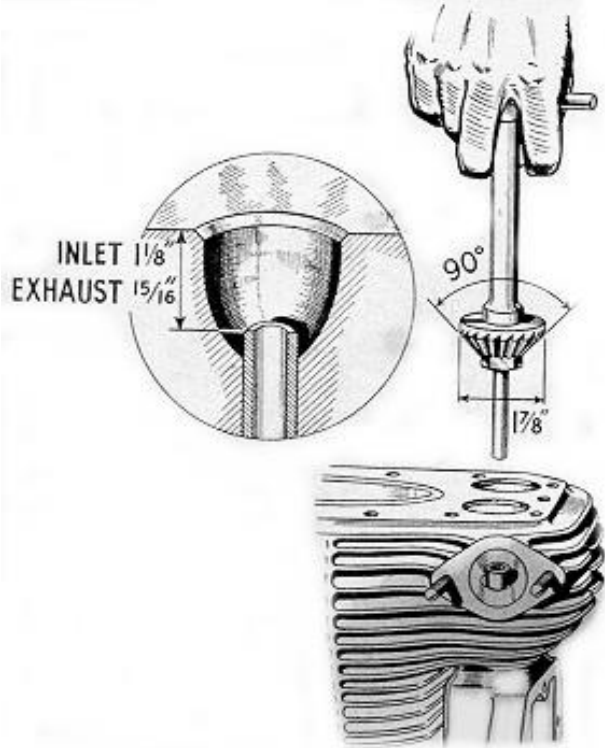

Fig. 14. Valve seating cutter and depth of guide.

care to remove all traces of grinding compound afterwards. A light spring, inserted under the valve head, considerably simplifies valve grinding, which should be continued until the valve face shows a

smooth surface all the way round. If the machine has covered a considerable mileage, the valve springs may need replacing. Refit the valves, springs and cotters with the aid of the tool shown in Fig. 12 after valve stems have been lubricated.

PISTON AND RINGS. The gudgeon pin is located by means of wire circlips which must be removed by means of a tang of a file or similar tool. Withdraw the gudgeon pin, thus freeing the piston and immediately after its removal mark the inside of the piston so that it can be re-assembled in its original position. If inspection of the piston rings shows that they are stuck, prise them out very carefully, and clean them. Remove any carbon from the grooves and rings, but before replacing them, check the gap with a ring in the cylinder. If the gap is excessive, new rings must be fitted having gaps of between .008" and .012" when in position.

At this stage it is advisable to check the big end bearing for wear. Turn engine until piston is at top of stroke, and resting both hands on sides of crankcase mouth, hold connecting rod between fingers and thumbs and feel for up and down play. It should be remembered that, even though there may be a little play present, it will not necessarily mean sudden failure of the bearing, though it will inevitably become worse. Where play seems excessive, and apparent big end noise has been noticed when engine is running, the engine should be completely dismantled, and a new big end assembly fitted.

Dismantling for decarbonising and piston inspection as described so far is carried out without removing the engine from the frame. Assembly from this point is described on Page 18.

REMOVING ENGINE FROM THE FRAME AND COMPLETE DISMANTLING

The procedure for the removal of the engine from the frame and dismantling will be described from the point reached in the previous section when the cylinder head and barrel have been removed. The oil pipes must next be disconnected, but first the oil tank should be drained. Alternatively the pipes can be disconnected and suitably plugged. Detach the leads to the dynamo (both of which are held by a small plate and one screw), and then the earth wire adjacent to the contact breaker housing. Follow these with the sparking plug lead. The magneto control cable can be readily detached from the handlebar lever.

REMOVING CHAINCASE

The oil bath chaincase follows next. Take off the footrest and then undo all the screws round the rim of the chaincase. The nuts of these screws are welded to the other half of the case and so cannot be lost. When the outer chaincase cover is taken off, careful note should be made of the positioning of the cork washers and distance pieces, to facilitate replacement. Before removing the chain loosen clutch as described in next paragraph, and then dismantle engine shaft cush drive. Tap the lock washer clear of the slot in the cush drive retaining nut and

unscrew the latter. Then withdraw the spring and cam sleeve, leaving the sprocket and chain in position. Next, take off the clutch.

REMOVING CLUTCH.

This can be accomplished with the aid of an extractor (shown in Fig. 30) after removal of the clutch outer cover, the actuating cap and the central sleeve nut. The extractor screws into the thread provided inside the clutch centre. Now uncouple the chain, the spring link being of the usual "hairpin" type. Take off the clutch as a unit and then the cush drive. There now remains the inner half of the chaincase, which is held to the crankcase by three bolts, wired together for locking purposes, and by a nut attaching the rear chainguard to the case. The nut can be released easily after the chaincase is pulled off the crankcase register.

The bolts holding the crankcase to the front and rear engine plates can now be removed and it is advisable to release the gearbox bolts in the case of the rear plates, since the latter clamp both gearbox and crankcase lugs between them. The frame bolt at the bottom of the front engine plates should be slacked off so that the plates may be swung

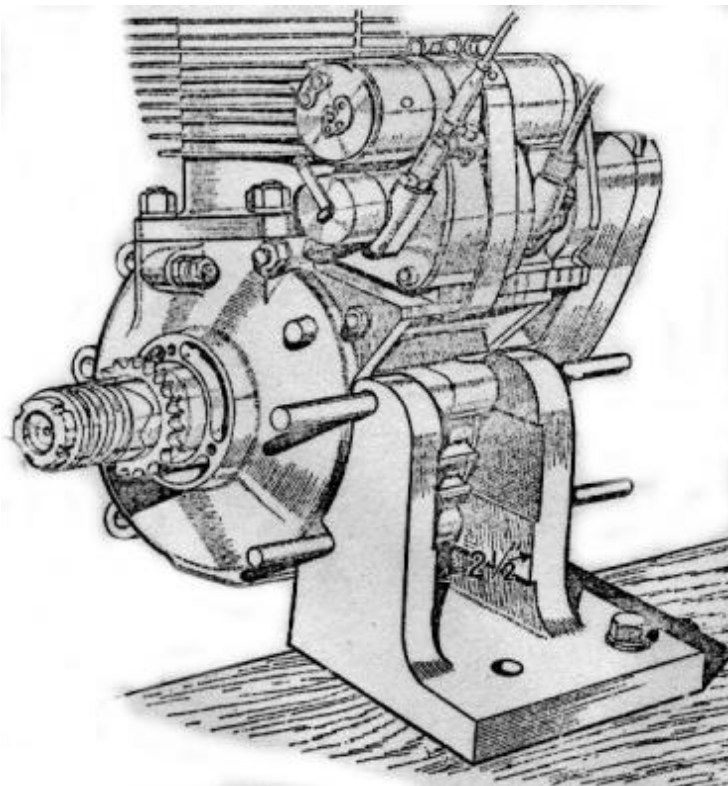

Fig. 15. Angle bracket for mounting engine.

forward, greatly facilitating removal of the engine.

DISMANTLING THE ENGINE

It is advisable before commencing to dismantle the engine to construct a simple fixture such as that

shown in Fig. 15 on which the engine can be mounted. Alternatively, a lug on the crankcase may

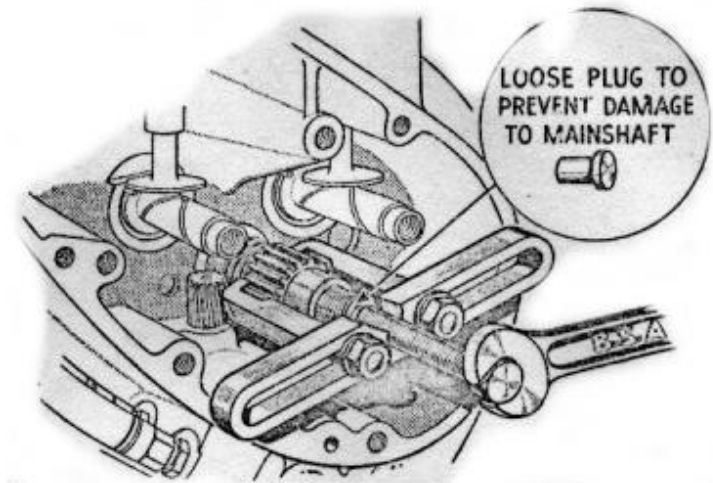

Fig. 16 Engine Shaft pinion extractor

be clamped in a vice and the crankcase itself supported on the bench.

Attention may next be given to the crankcase portion of the engine. Take off the timing cover, and if any difficulty is experienced in releasing the screws, it will facilitate matters if a long screwdriver is used, and the head given a sharp tap with a mallet. On some models an oil tell-tale is fitted on the timing cover and this must also be taken off. It is possible that the jointing compound on the case between the cover and crankcase will not allow the cover to be removed easily and in this event, the lugs on the end of the cover should be used to tap it off. Take care not to damage the small nozzle in the timing cover which feeds oil to the hollow crankshaft; if it should be refitted in a bent condition it will foul the mainshaft, and break off eventually, thus starving the big end and piston of oil.

REMOVING MAGDYNIO PINION

Next, the magdynio pinion should be removed. Since the pinion fits on to a taper shaft difficulty may be experienced in removing it. It is not advisable to attempt to prise the pinion off with levers, as there is a grave risk of breaking the timing case, but it will come off quite simply provided an extractor to that shewn in Fig. 10 is used.

Note that there is a special oil seal fitted in the timing case, behind the magneto pinion. It is only necessary to release the magdynio strap bolt, when the straps can be swung on one side, and the magdynio lifted off. The latter is located by dowels only, and if any shims were fitted below the magdynio they should be carefully preserved.

The engine shaft nut should be removed and the plate holding the timing gears in position is detached by removal of the six fixing bolts, three of which screw into the crankcase casting and have coarse threads, while the remaining three screw into the pinion spindles and have fine threads. All the pinions can now be withdrawn with the exception of the engine shaft pinion which may require an extractor. The latter is shown in Fig. 16, and in order to prevent damage to the engine mainshaft, a flat headed pin of suitable dimensions should be inserted in the oil hole, in the manner illustrated. If the pinions are re-bushed they should be reamed out to .6255"/.6250" for the cams and .7505"/.7495" for the idler pinion. The correct size for the outrigger bearing in the timing gear plate is .815"/.814".

Before the oil pump spindle is released it is first necessary to remove the locking plunger which is exposed after removal of the timing cover (Fig. 17). Take care not to lose the loose washer covering the plunger. If the latter cannot easily be removed with the fingers, a timing cover screw should be screwed into the plunger, when it can easily be withdrawn. If it is necessary to remove the pump take off the sump

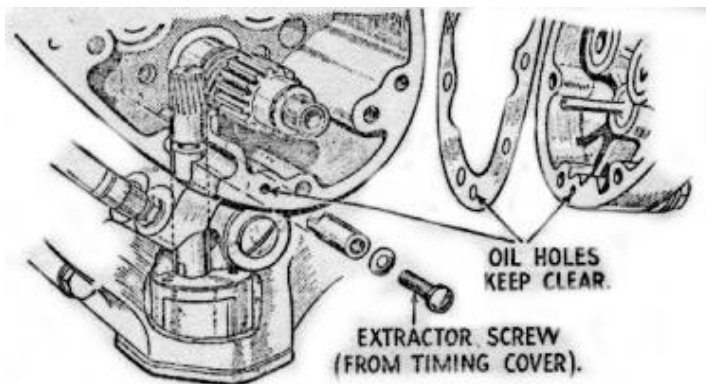
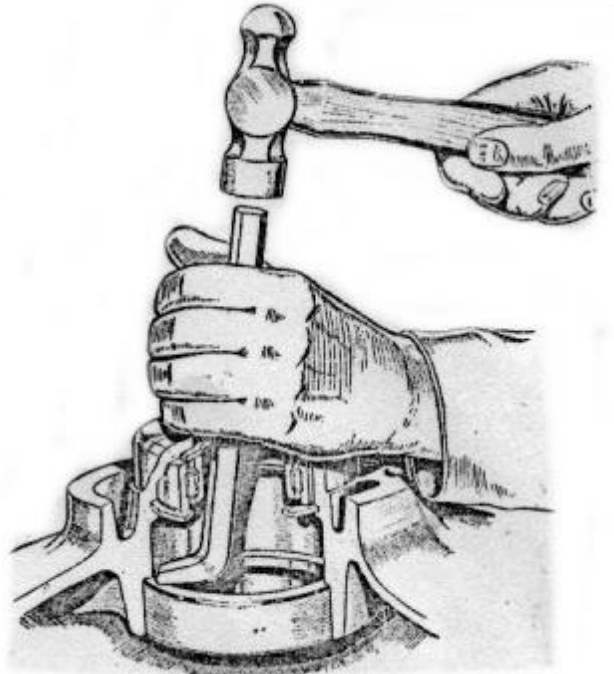

Fig. 17 Oil pump spindle locking plunger

cover plate, together with the filter and joint washers, and remove the two bolts holding the pump in position, thus releasing the pump. These two bolts are the ones with spring washers under the heads; the other two bolts hold the pump parts together and should not be disturbed unless it is strongly suspected that the pump is giving trouble.

The crankcase is now ready for "splitting". Release all the bolts around the crankcase joint face (the magneto strap hinge pins also act as bolts and the nut on these must be removed) and draw each half of the crankcase off the engine mainshaft. Where single lipped roller bearings have been used in the engine, the outer race will remain in the crankcase and if necessary can be pressed out later. It should be remembered that the outside bearing on the drive side has its outer race retained in the crankcase by

means of a spring ring which must be removed before extracting the race.



Ball bearings will usually be left on the shafts after removal of the crankcase halves, but should they remain in the crankcase, they may be pressed out of the gearside in an arbor press as shown in Fig. 19. On the drive side the inner bearing must first be tapped out with a punch, projecting through the outer bearing and, working all round the

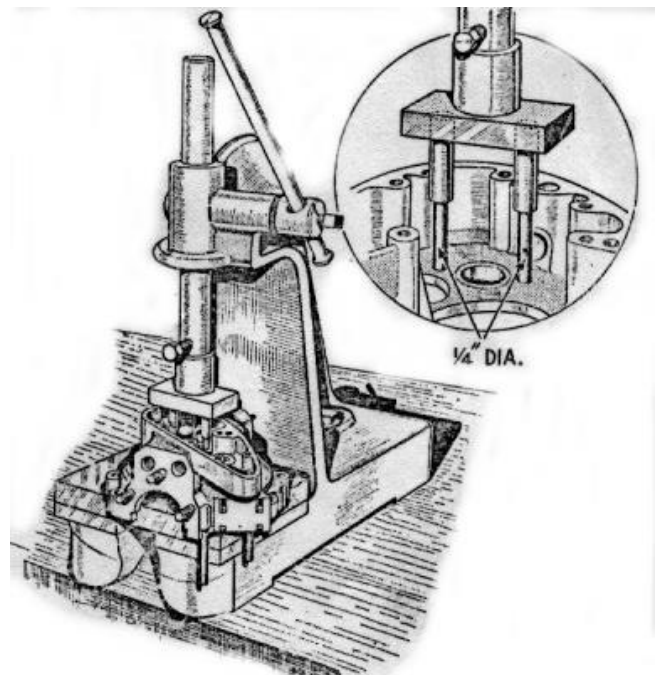

Fig. 19. Ballrace extraction (gearside)

Bearing to give even extraction (Fig. 18). These operations will be considerably helped if the crankcase is first warmed, the most suitable method being by dipping in boiling water.

If it is desired to remove the cam pinion spindles, they can easily be taken out by means of an extractor (Fig. 20). **Do not remove these spindles unless absolutely necessary.** If the tappets require renewal, then the cam spindles and tappet guides must be withdrawn so that the tappets can be drawn out downwards into the timing case. The exhaust tappet requires special treatment, and should not be replaced by an inlet tappet. The tappet guides unscrew upwards out of the crankcase.

The final item is the flywheel assembly. Remove the locking plates holding the crankpin nuts and take off the latter. They will require an unusually large leverage and it may be necessary to add a piece of tubing of suitable size to the spanner before sufficient purchase can be obtained.

The crankpin is a taper fit on the flywheels and can be released by a sharp blow with a mallet. It is now only necessary to decide which parts require renewal, and the following points may be of assistance in making these decisions.

In the event of big-end wear, we do not advise the fitting of oversize rollers; the whole big end assembly (consisting of crankpin, rollers and connecting rod), should be changed. All these components are carefully matched by the B.S.A. Co., and supplied in complete sets ready for fitting.

The bore of a cylinder when new is between 3.2295" and 3.2280" (82mm) and when the bore (measured at right angles to the gudgeon pin) shows wear to the extent of .010" or more, the liner should then be rebored to ½ mm. oversize (3.2487" – 3.2477") and a ½ mm oversize piston fitted. Subsequently, the liner may again be rebored, to 1 mm. oversize (3.2684" – 3.2674") and a 1 mm. oversize piston fitted.

When wear develops after the second rebores, it is necessary to fit a new cylinder liner. A suitable screw or hydraulic press giving a pressure of between 5 and 7 tons is necessary – first to press out the old liner (which must be pressed out from the base of the cylinder) and then to insert the new liner, which is pressed in from the top of the cylinder. Owing to the possibility of the liner "closing-in" during the fitting process, it must be ground to a finished diameter of 3.229" – 3.228" when in position.

It is also necessary to grind two scoops at the skirt of the liner at right angles to the gudgeon pin to provide

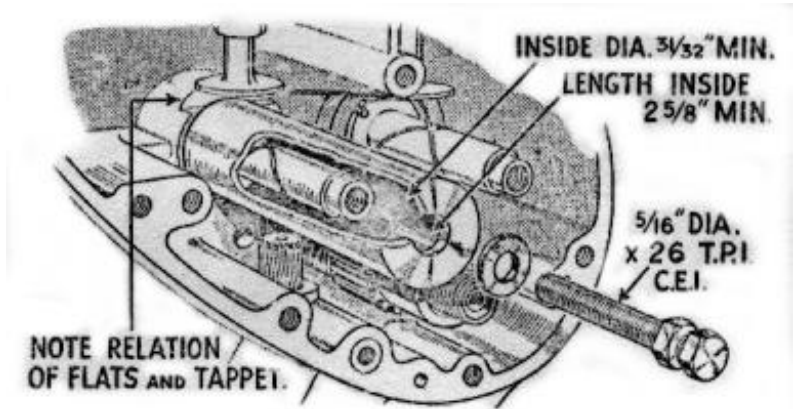
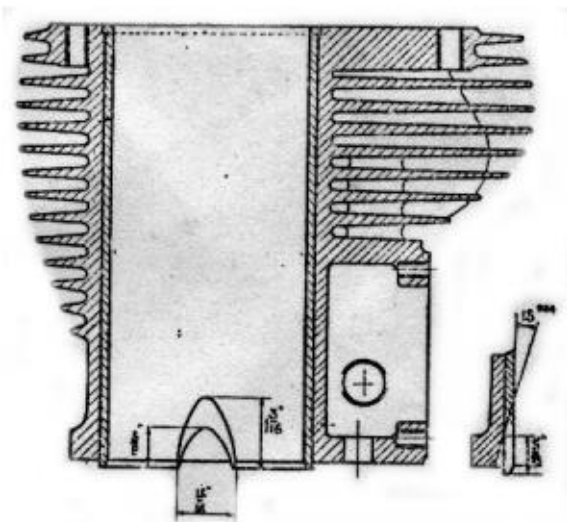

Fig. 20 Cam pinion spindle extractor.

clearance for the connecting rod (see illustration below).

A standard piston and rings must of course be fitted when a new liner is used. The piston should be selected so that the clearances between the skirt and the liner fall within the prescribed limits given in Technical Data (page 2).

Wear in the mainshaft bearings will be readily apparent and bearings showing signs of damaged balls, rollers or tracks should be replaced. Special internal clearances are specified for mainshaft bearings used on B.S.A. motor cycles, and these are "000 clearance" for roller bearings and "00 clearance" for ball bearings. It is not advisable to fit bearings with any other clearance.



Two scoops diametrically opposite, ground after liner is pressed in.

RE-ASSEMBLING THE ENGINE

The need for extreme cleanliness cannot be over-emphasised.

Parts should be thoroughly cleaned and all trace of any antirust preparations with which new parts may be coated must be removed.

All bearing surfaces should be liberally smeared with engine oil when assembling.

FLYWHEELS

If the big end assembly is to be renewed it is as well to check the weight of the new components against those which have been removed. A slight variation in the weights is inevitable, but provided that the discrepancy does not exceed 1 ½ oz no further action need be taken. This tolerance should not be exceeded since in the first instance the flywheels have been balanced to suit the original parts, and the balance may be adversely affected if the weight of the new components varies considerably from that of the original ones.

The driving side flywheel should now be fitted to the crankpin (this is the side with the keyway) and the nut tightened up by hand. Fit the timing side flywheel and again tighten the crankpin nut by hand.

In order properly to tighten the crankpin nuts, the whole flywheel assembly must be held rigidly. For this purpose, it should be mounted in a large vice (fitted with lead clamps) with the driving side flywheel uppermost. If a large enough vice is not readily available an alternative method is to fix rigidly to the bench in a vertical position, two 1 1/16" diameter posts, the distance between their centres being 3 7/8". Midway between the posts a hole of 1" diameter should be bored in the bench to receive the mainshaft. The flywheel assembly is mounted on these posts so that they pass through the holes bored in the flywheels and the driving side flywheel should be uppermost. Tighten the crankpin nut **very firmly**, using a tubular extension to the spanner as when dismantling, and fit the locking plate and screw.

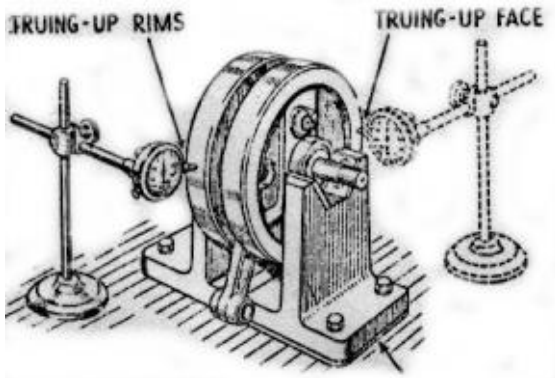

Suitable packing under timing side "vee" block to compensate for smaller diameter bearing.

Fig. 21. Checking flywheel alignment.

Now turn the assembly over, so that the gearside flywheel is on top and tighten the crankpin nut lightly. The grub screw in the end of the crankpin must be

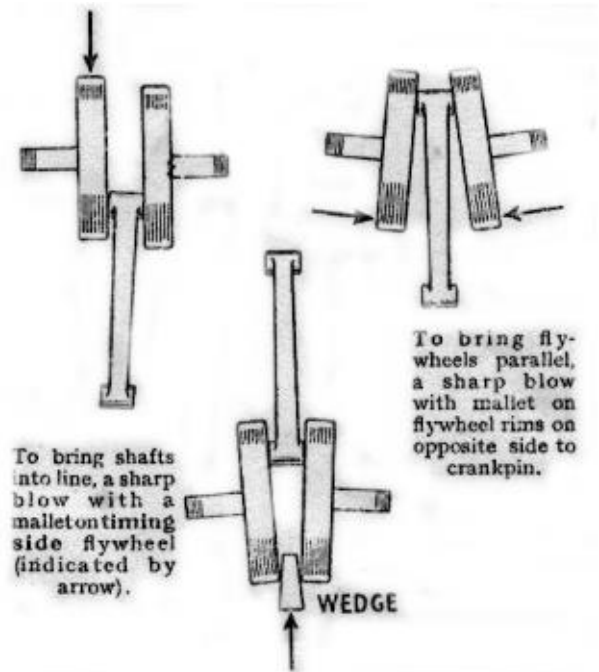

To bring flywheels parallel when sides opposite Crankpin are converging insert wedges as shown and deal sharp blow with mallet.

Fig. 22. Method of correcting flywheels out of alignment. Note that above illustrations are greatly exaggerated.

riveted over or centre-punched to prevent its unscrewing. If it unscrews serious damage may result to the engine. Check that the side clearance of the connecting rod in the flywheels does not exceed .012" and is not less than .010".

The flywheels will now be aligned only very approximately and further steps must be taken to ensure that the wheels are aligned as true as possible. Two of the actual (or similar) bearings to be used in the engine should be fitted to the mainshafts and the latter mounted on vee-blocks. The flywheels must be trued up, both on faces and rims, for which purpose a dial micrometer is necessary (Fig. 21), and after the wheels are trued to within at least .005" tighten the timing side crankpin nut fully. A mallet or lead hammer applied to the flywheels will provide a sufficiently heavy blow for final truing, and will not harm the flywheels (Fig. 22). The shafts must not be struck. The shafts should be finally trued to within .002" maximum.

CRANKCASE

Withdraw the bearings from the shaft and press them into their appropriate positions in the crankcase halves. A new washer will be required behind small drive bearing and a new retaining ring must be fitted. In the case of single lipped roller bearings only the outer race can be so fitted. Do not omit the retaining ring which holds the driving side bearing in position, and check the ends of the spacing sleeve between the bearings are parallel to within .002". In order that the inner bearing and the sleeve will stay in position it is advisable to lay the crankcase half on a bench with the outer bearing lowest.

Fit the oil flinger washer to the driving side mainshaft and note that this washer is bent over in one place to prevent accidental movement when fitting. If a new washer is being used it should be bent in a similar manner to the one which has been removed. Insert the driving shaft carefully into the crankcase, taking care not to disturb the flinger washer. The shaft should fit into the bearing without the use of unnecessary force and although the shaft must be a fairly tight fit in the bearings, it should be possible to assemble it by hand. If necessary ease the shaft with emery cloth, **carefully cleaning off any trace of emery afterwards.**

It is advisable to attend to the timing side of the crankcase before continuing further. Replace the oil pump driving spindle together with its locating pin (see Fig. 17) and then fit the oil pump in position.

The fibre washer between the pump and crankcase should be smeared with jointing compound, **but an excessive amount must not be used, since any surplus will be squeezed out and may find its way into the oil passages.** The pins securing the oil pump must not be screwed up too tightly. Check that the pump spindle can be rotated between finger and thumb.

Now replace the tappets and guides, the latter being screwed well home, and insert the cam pinion spindles. **These should be pressed home taking great care to keep them dead square, and must be fitted so that the flat on the spindle shoulder is parallel to the tappet foot, for which it provides clearance and consequently its position is most important.**

Assembly of the crankcase will be made easier if the flywheel assembly, together with the driving side portion of the crankcase fitted on as previously explained, is mounted in a vice. Lead clamps must be used and the splined portion of the shaft held. The mainshaft bearings may now be pressed into the gearside half of the crankcase and the latter replaced on the mainshaft. Bolt up the crankcase and check that the flywheels, etc., spin easily. Fit sprocket centre, tighten up, and verify also that the connecting rod is centrally disposed in the crankcase mouth. Provided

that the connecting rod is not visibly out of centre, there is no necessity for any adjustment to be made. If the connecting rod is out of centre, it will be invariably be towards the driving side of the crankcase. In this event a shim will have to be made and inserted between the driving side flywheel and the oil flinger washer. It may be also that the distance sleeve between the driving side bearings has become a little worn on its end faces, and a new component (one specially chosen so that its length is on the maximum limit) will rectify the connecting rod alignment. The maximum length for the distance sleeve is 1.005" and the minimum is 1.000". When the connecting rod alignment is found correct, remove the gearside half of the crankcase and clean the joint of any compound used previously. Fit the magdyno straps on their hinge pins, smear jointing compound lightly on the crankcase joint face and again bolt up the crankcase. Check that top of the crankcase, where cylinder base flange fits, is dead flat.

TIMING GEARS

Replace the engine shaft pinion, taking special care to note that the worm is engaging properly with the oil pump spindle and that rotation of the flywheels drives the pump.

The cam pinions are interchangeable and consequently the timing marks are duplicated on both pinions. This should not cause any difficulty when timing the valves if it is remembered that the dash mark only is used for the inlet cam and the dot for the exhaust cam. (Fig. 23).

The magdyno can now be fitted to the crankcase and its straps loosely coupled up. Make sure that the dowels in the base engage properly in their holes in platform and that any packing shims are refitted. Refit the idler pinion between the inlet cam pinion and the magdyno pinion, but do not replace the pinion retaining plate at this stage.

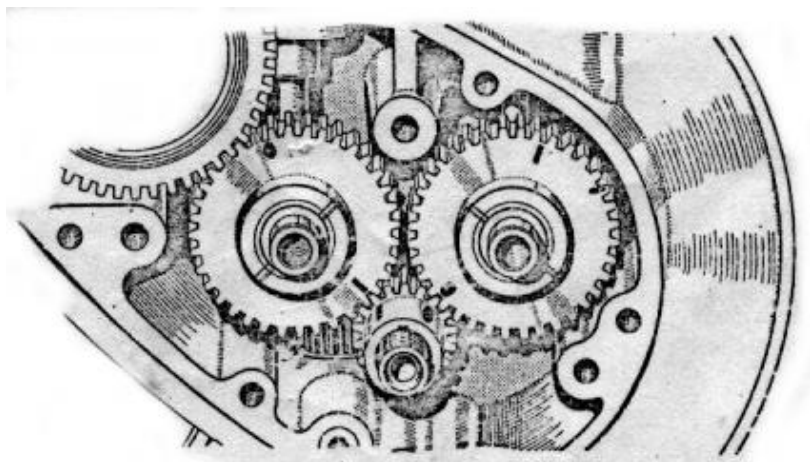

Fig. 23. Valve timing marks.

An oil sealing washer is fitted behind the magdyno pinion and this should be temporarily removed. Replace the magdyno pin on its taper; it need

not be driven on very firmly but just tightly enough to prevent slip. Check the backlash between this pinion and the idler. If excessive, the gears will be noisy; if insufficient, a whining noise will result.

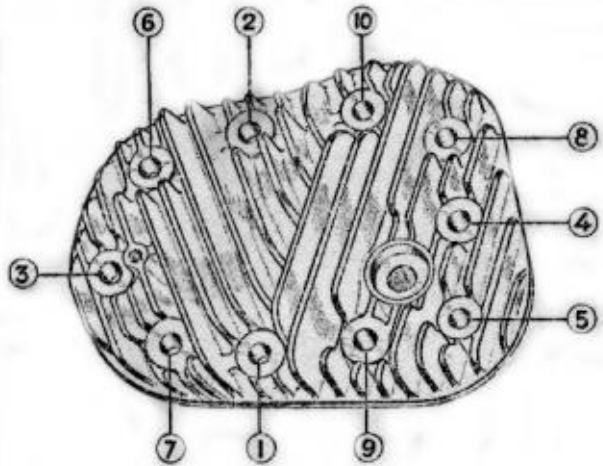

Fig. 24. Cylinder head bolts.

In order to adjust the backlash, shims are fitted under the magdyno if necessary, when the engine is first built. If a different magdyno is being fitted it is essential this backlash be checked carefully, shims of a different thickness being used as required.

Remove the magdyno pinion once more, replace the oil sealing washer and again fit the magdyno pinion **loosely** in position. It is preferable to leave the setting of the ignition until the barrel and piston are in position, and for this reason the magdyno pinion should not be tightened up. The valve timing can now be set. Replace the pinion retaining plate, noting that the coarse threaded bolts screw into the crankcase bosses and then fit the lockwasher and nut on the engine mainshaft. Play between the pinions and the retaining plate should be .002"/.003".

ASSEMBLY FROM THIS POINT WILL BE THE SAME AS AFTER DECARBONISING.

CYLINDER AND PISTON

The gap between the ends of the rings should be checked with the ring in the cylinder. If the gap is excessive new rings should be fitted with gaps of .008"/.012". Replace the piston and gudgeon pin on the connecting rod and if the original piston is used make sure that it is the correct way round (see Page 12). Do not omit the gudgeon pin circlips and verify that they are properly fitted.

Set the tappets on their lowest position, fit the paper washer on the cylinder base and replace the cylinder barrel on the crankcase. The piston rings may be

compressed quite easily by hand while the barrel is being replaced.

Tighten the barrel down, not forgetting one nut is inside the tappet chest. The tappet clearances should be set very carefully as described on pages 8 and 9.

Next set the ignition timing as described on Page 9. Note that as the magneto cable is disconnected the cam will be in the "full retard" position and it must be held in the "full advance" position.

The resetting of magneto timing will not apply after decarbonising as there is no necessity to disturb the timing to remove the cylinder head and barrel.

Replace the timing cover after lightly smearing both sides of its paper washer with jointing compound, **taking care that the oil hole (Fig. 17) is not obscured.** (This does not apply after decarbonising). Bolt the cylinder head and gasket in position, but if the latter shows signs of leakage from previous use (indicated by black patches) a new one should be fitted. The cylinder head bolts must be tightened down in the order shown in Fig. 24.

The exhaust valve lifter body may now be screwed into its original position. Before the sparking plug is replaced it should be dismantled and cleaned, or if the machine has covered a large mileage a new plug should be used

Replace the tappet cover and lightly smear the washer with jointing compound before fitting.

The engine is now ready for bolting into the frame (This does not apply after decarbonising), and after replacement check that the bolts are really tight, and that the gearbox bolts have not been forgotten. Refit right-hand footrest assembly pushing rod fully home.

The near-side footrest sleeve and distance piece (behind chaincase) should now be placed in position. Then refit the inner half of the chaincase (first

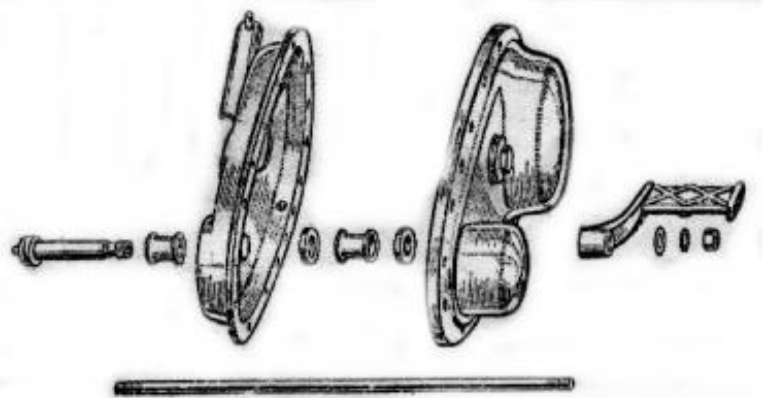

Fig. 25. Assembly of chaincase and footrest.

checking that oil-seal washer is in good condition) and when the bolts holding it to the crankcase have been finally tightened, wire them together with a fresh piece of wire for locking purposes.

The engine shaft cush drive can be replaced by hand, without the need for special tools to compress

the spring (this does not apply after decarbonising).

Lock the central nut up tight, when the clutch and primary chain are in position.

Fit the clutch on the gearbox mainshaft (this does not apply after decarbonising) – see re-assembly of clutch, page 22 – and replace the chain. On fastening the spring link it is important that it should be fixed so that the closed end is pointing in the direction of the “run” of the chain.

When replacing the chaincase outer cover, make sure that the washers, etc. on the footrest bar are in the correct position (see Fig. 25) and that the jointing washer is properly fitted. The chaincase must be

refilled with engine oil to the level plug, before the machine is used.

If there is any suspicion that the rubber pipes from the oil tank to the crankcase are faulty they should be replaced, otherwise the engine may suffer harm from insufficient oil. Note that in later models, the oil pipes are metal with a short rubber insertion.

All the control cables (i.e., carburettor, magneto and exhaust valve lifter) should be re-coupled next, followed by the dynamo leads and the earth wire.

Finally, replace the petrol pipe and then the exhaust pipe and silencer.

TRANSMISSION

Adjustments which can be carried out without dismantling

CLUTCH ADJUSTMENT

Two adjustments are provided at the clutch control arm on the gearbox outer cover. The adjustment, which is for the clutch push rod will be exposed when the rubber cover at the base of the arm is moved aside and consists of a grub screw and locknut. Between the inner end of the screw and the clutch push rod a steel ball is inserted and the grub screw must be adjusted so that there is just a little clearance between the ball and push rod. The control arm in the declutched position should be as upright as possible.

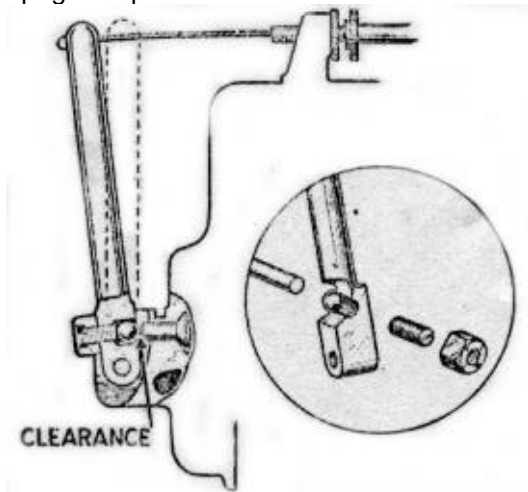

Fig. 26. Clutch control adjustment.

The second adjustment is for the cable itself. If the control arm has been set in a new position, the cable length is altered to suit by means of the thumb nut on the cable stop above the gearbox.

FRONT CHAIN ADJUSTMENT

The front chain is adjusted by moving the gearbox. The latter slides between two plates and cannot, therefore, cause chain misalignment.

Release the gearbox fixing bolts and move the box by means of the screw adjuster (see Fig. 27) until the chain has about $\frac{1}{2}$ " total play at a point about mid-way between its sprockets. The chaincase filler plug can be used as an inspection cover for this purpose, or alternatively, the chaincase outer cover

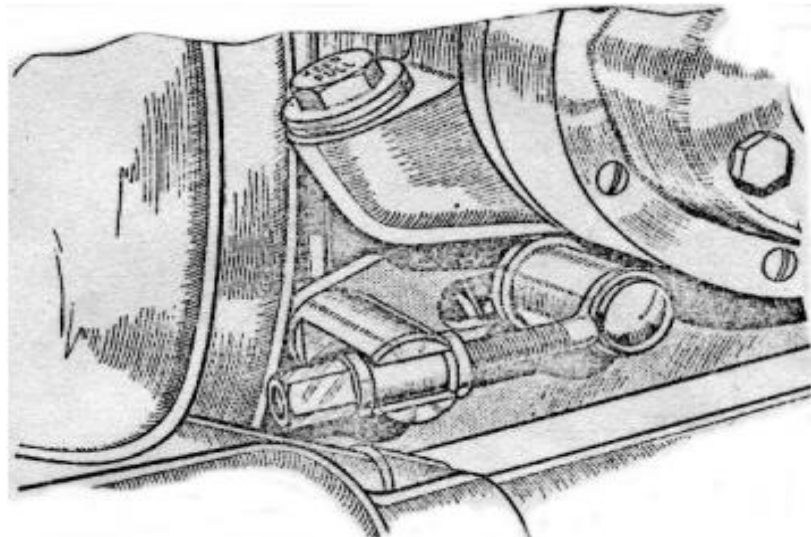

Fig. 27. Front chain adjuster

can be taken off. Make sure that the adjustment is correct for all positions of the sprockets and that the gearbox bolts are well tightened.

REAR CHAIN ADJUSTMENT

The rear chain is tensioned by means of a special cam on the nearside of the wheel spindle and by screw adjustment on the offside. First, release the offside spindle nut (see Fig. 28), then the cam locknut on the nearside. The latter nut is the larger of the two nuts on this side. Then, applying a spanner in an anti-clockwise direction to tighten the chain, until it has a total amount of play, mid-way between the sprockets, of about $\frac{3}{4}$ ".

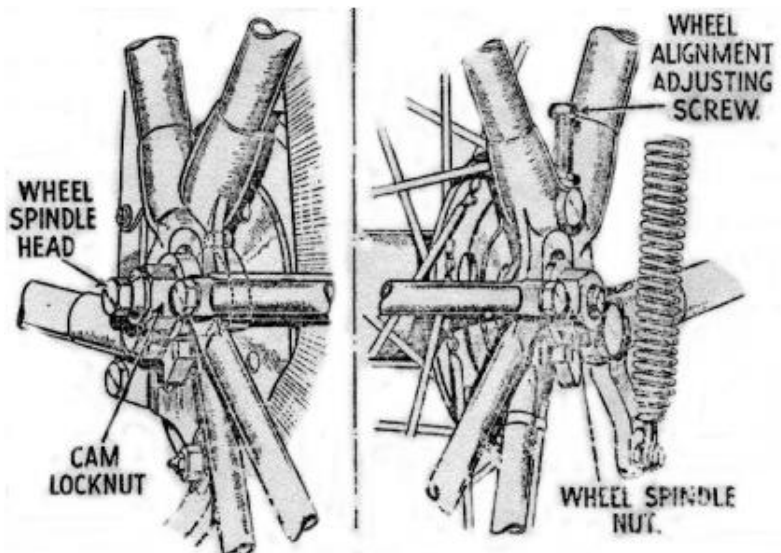

Fig. 28. Rear Chain adjuster.

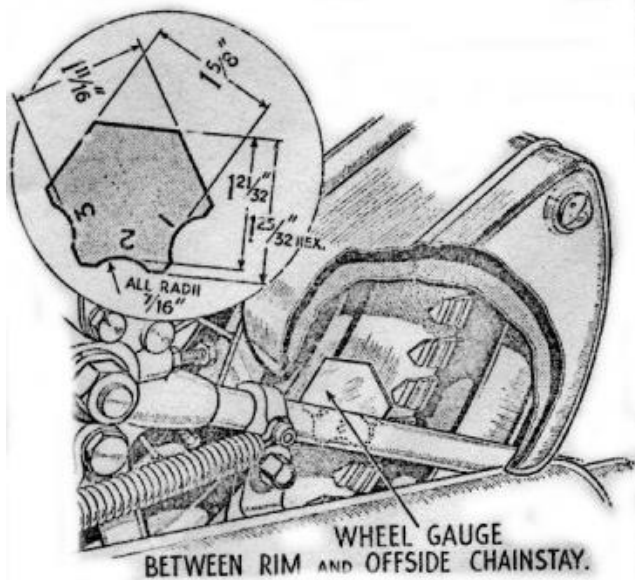

Fig. 29. Wheel alignment gauge.

Now turn to the offside of the machine and screw the adjuster in (if the chain has been tightened) until the wheel is properly aligned in the frame.

A gauge is provided in the tool kit for this purpose, and fits between the offside chainstay and the wheel rim (Fig. 29). (Before the gauge is used it is

necessary that the wheel alignment be checked with a straight edge and the see which gauge – 1, 2 or 3 – is the correct fit). If the machine is in the workshops, however, it is much better to use a wooden straight edge, in the normal manner, i.e., it should touch each wheel in two places. Tighten the cam locknut and check the chain setting. If correct, tighten the offside spindle nut and then the offside adjuster locknut.

NOTE: It may be necessary to adjust the rear brake, since this will have been altered by movement of the rear wheel.

DISMANTLING AND RE-ASSEMBLING THE CLUTCH

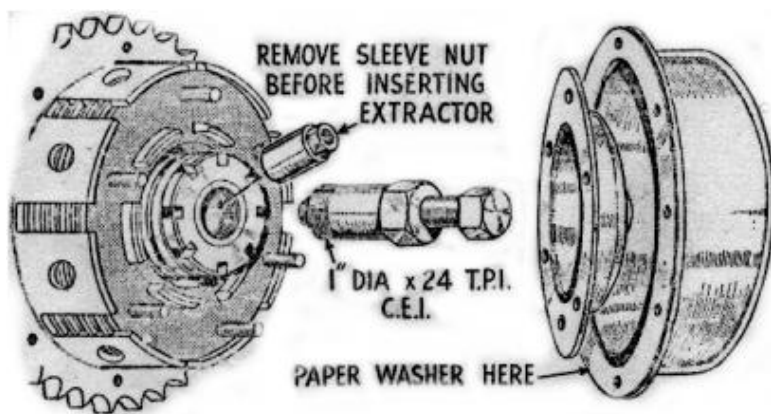

Fig. 30. Clutch extractor tool.

Take off the left footrest and then undo all the screws around the rim of the chaincase. The nuts of these screws are welded to the other half of the case, and so cannot get lost. As the outer chaincase cover is taken off, careful note should be made of the repositioning of the washers, etc., for replacement purposes (see Fig. 25). The joint washer should be carefully preserved.

The clutch is next to be removed exposing the clutch pressure plate, which in turn can be taken off after

removal of the six nuts. By unscrewing the central ring nut all the clutch plates, both steel and fabric, will be released. Take care that the spring does not fly off as the nut is removed.

The clutch hub is held to the gearbox mainshaft by means of a sleeve nut through which the clutch push rod will be seen to protrude. Unscrew this nut and apply the extractor as shown in Fig. 30, thus drawing the remainder of the clutch off the mainshaft.

The various parts may now be examined for wear. Special attention should be paid to the slots in which the steel plates slide and if any grooves worn in them are not too deep

the sides of the slots can be filed smooth. If the sprocket teeth are worn to a hook shape the sprocket must be replaced, otherwise rapid chain wear will result. The steel plates should be smooth and if they are badly scored should be replaced, while the fabric rings will require a thorough washing in petrol if there is any trace of oil on them. Finally, examine the rollers and tracks and verify that the cork washer is intact.

RE-ASSEMBLY OF THE CLUTCH

The clutch is of straight-forward construction and a study of Fig. 32 will show how the parts are

No adjustment is provided for altering the tension of the ring and the ring must be screwed up tight. After carefully centralising sliding plate (in ear half of chaincase) with gearbox mainshaft, refit clutch assembly to mainshaft after cork washer and key have been placed in position. Screw home and well tighten sleeve nut.

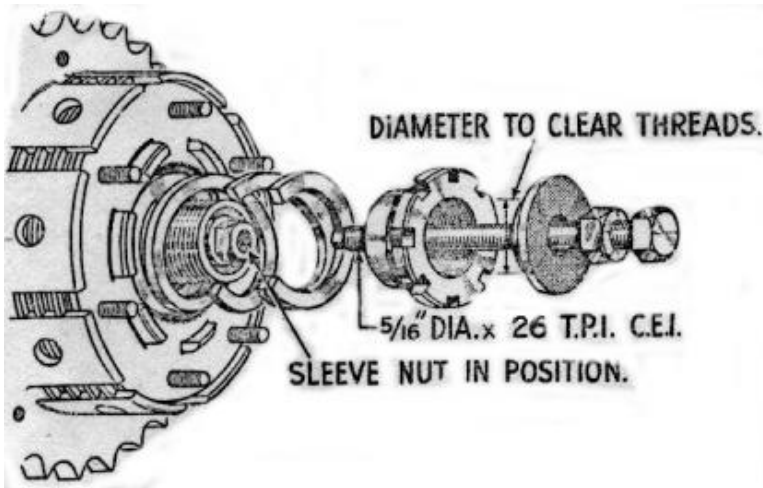

Fig. 31. Clutch assembly tool.

assembled. It is important to note that the cork

washer must not be omitted as this is for the purpose of preventing oil reaching the clutch. The plates must be fitted in their proper order, as follows: Fabric disc, driven plate (tongues on outer diameter), fabric disc, driving late (tongues on inner diameter), etc., stating and finishing with a fabric disc of which there are eight.

Difficulty may be experienced in compressing the spring before the central ring nut can be started on its threads, and a suitable bolt and washer used as illustrated in Fig. 31 will enable the sprig to be compressed sufficiently for the ring nut to be screwed home.

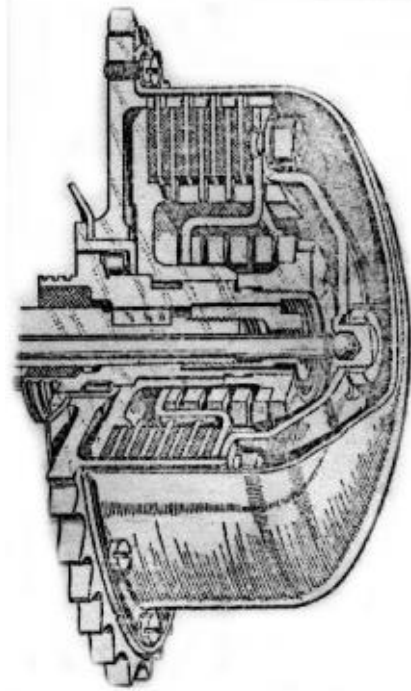

Fig. 32. Section through clutch.

Refit clutch actuating cap (first smearing small quantity of grease on ball in centre) and finally replace clutch cover. When replacing the clutch cover verify that the paper washer is in position and it should be lightly smeared with jointing compound before assembly, to ensure an oil-tight joint.

REMOVING, DISMANTLING AND RE-ASSEMBLY OF THE GEARBOX AND GEAR CHANGE

REMOVAL

Instructions as to the procedure to be adopted for removal of the chaincase and clutch are contained in the Chapter on "Dismantling and Re-assembly of the Clutch." In this case, however, there is no need to

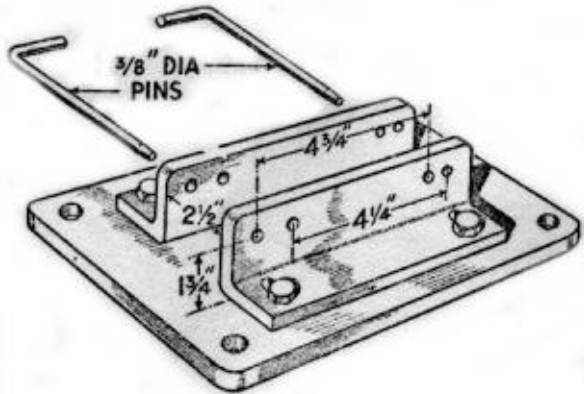

Fig. 33. Gearbox Fixture.

dismantle the clutch entirely; it is only necessary to take off the cover plate and thrust plate when the clutch may be withdrawn from its shaft as a complete unit. Before this is done, ie with chain and clutch still in position, it is advisable to engage a gear, and get an assistant to apply the rear brake, so that the engine shaft cush drive ring nut may be unscrewed, thus releasing the cush drive assembly. Uncouple the primary chain and remove the clutch using the extractor shown in Fig. 30.

The inner half of the chaincase can now be taken off. Note that in addition to the three bolts holding it to the crankcase, there is a nut attaching the rear chainguard to the chaincase and this must also be removed. Access to the nut will be made much easier if the three crankcase bolts are unscrewed first and the chaincase pulled off the crankcase register. The oil tank breather pipe is next to be removed and this is only a matter of releasing the clip bolts. Turning now to the right-hand side of the machine, first take off the footrest, then uncouple the clutch cable from its operating arm and unscrew the cable adjuster from the gearbox.

In order that the bolts which hold the gearbox to the yoke plates may be removed it is necessary to take off the exhaust pipe and silencer.

The box itself can be prised upwards out of the yoke plates. If the latter grip the gearbox lugs too tightly for this to be carried out easily, slacken the bolts and studs which clamp the yoke plates to the crankcase. No difficulty should then be experienced in removing the gearbox.

DISMANTLING THE GEARBOX

It will greatly help work on the gearbox if it is held in a simple fixture such as that illustrated in Fig. 33. The device can be made from suitable pieces of angle iron, spaced to suit the gearbox lugs. If it is not possible to make the fixture, gearbox can be held in a vice.

Commence dismantling by taking off the rectangular inspection cover and follow this with kickstarter crank. The latter is fixed by means of a cycle type cotter. The foot change pedal is held in position by means of a pinch bolt which must be slackened off before the pedal can be removed. Behind this pedal are two circlips, the larger one being removed, followed by the gear indicator disc. Leave the small circlip in position for the time being.

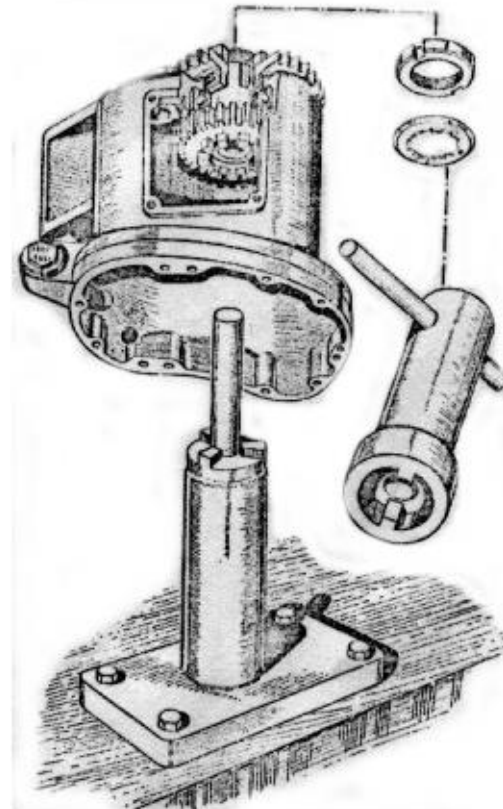

Fig. 34. Pinion sleeve removal tool.

The gearbox outer cover is now ready for removal. It is held on seven cheese head screws and, on the face behind the gear change mechanism, by three bolts and on nut. When the outer cover is taken off, it will contain the kickstarter quadrant and spring, but these need not be disturbed unless obviously requiring attention.

Next, remove the pin from the link rod between the selector quadrant and the gearchange mechanism at the latter end and unscrew the nut off the end of the gearchange spindle. The gearchange mechanism can now be taken out as a complete unit, and dismantled later. Take care not to lose the small plunger and spring exposed by the removal of the previous parts.

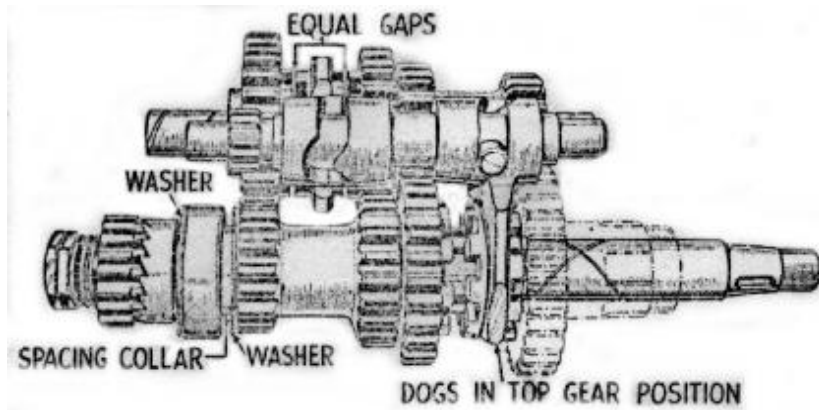

Fig. 35. Gear train.

The ratchet mechanism on the mainshaft must be dismantled next. First unscrew the locknut, straighten the tag washer, and remove it. By unscrewing the next nut, all the remaining parts of the ratchet mechanism will be free and can be taken off.

There is now no obstacle to the removal of the gearbox inner cover except for its fixing screws of which there are four. Two of these are fixed by a locking strip and the ends of this must be straightened before the screws can be removed. As the cover comes off, it will contain the mainshaft ballrace, and leave exposed loosely on the mainshaft an oil flinger (thin) and spacing collar (thick).

Also assembled on the inner cover is the gear selector quadrant, but here again this need not be disturbed unless attention is obviously required. If it has to be removed, take care not to lose the plunger and spring and make sure they are re-fitted when assembling.

If, when the inner cover is withdrawn, the three shafts (main, lay and selector) also come out still assembled in the cover, they may be quite easily detached, as they are a running fit in their bushes. In the same way if the shafts are still in the box, after removing the gearbox cover, they can be withdrawn with similar ease by removing all the shafts together. The layshaft bushes are, of course, a press fit in the gearbox and, if necessary, must be driven out with the aid of a soft punch ($\frac{15}{16}$ " diameter).

The top gear pinion sleeve is now the only part still left in the gearbox, and if the sprocket locknut is unscrewed, after suitable attention to the tag washer, the socket may be removed and the pinion tapped into the gearbox with the aid of a wooden mallet. If difficulty is experienced in holding the pinion whilst the sprocket is unscrewed, a fixture similar to that in Fig. 34 will solve the problem.

Do not disturb the ballrace unless it is suspected of being faulty. Wash it thoroughly in paraffin, to remove all traces of oil, when any play will be immediately detected.

Examine the various parts for wear and if the forks, which actuate the sliding dogs, show signs of seizure it is advisable to replace them. Attempts to erase the seizure marks will result in excessive side play.

Replacement sliding dogs may be found to have convex faces on the dogs but this will not affect interchange ability, if the originals had flat faces.

Loose pinions on the lay and mainshafts may be rebushed if required, and of course, pinions with damaged teeth should also be replaced.

Fixed pins on the layshaft and mainshaft are pressed on and new components must be a tight fit.

DISMANTLING THE GEARCHANGE MECHANISM

It is only necessary to prise the two pawl springs off their pegs, and to remove the circlip, when the whole unit can be stripped into separate components. The only parts which are likely to show signs of excessive wear are the pawls and the ratchet plate, and new components should be fitted if required. If the pawl springs show signs of stretching, they too, should be replaced.

RE-ASSEMBLY OF THE GEARBOX AND GEARCHANGE MECHANISM.

If it has been decided to fit a new ballrace to the top gear pinion, make sure that the oil flinger washers are correctly positioned. In order to remove the ballrace easily, warm the gearbox in boiling water. The flat washer should be placed between the pinion teeth and the bearing while the remaining washer fits on the opposite side of the bearing with its depressed

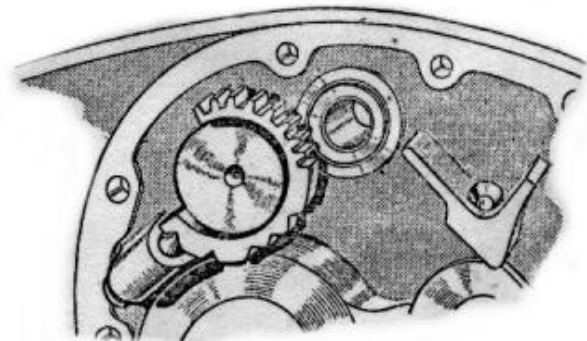

Fig. 36. Selector quadrant

face against the bearing. If the sprocket teeth are worn hook shaped a new one must be fitted, otherwise rapid chain wear will result. Do not forget to set the lockwasher into the grooves machined in the locknut after the latter has been tightened up. The tabs in the centre of the locknut washer must fit properly into the sprocket splines.

It is only possible to refit the shafts and their pinions in the box provided that the shafts are first assembled (with pinions in top gear position) outside the gearbox and then all fitted together.

Commencing with the layshaft, take off the low gear pinion only (this is the largest on the shaft) and hold the shaft in the left hand with the drilled end towards the wrist. Take up the selector shaft and fit the fork nearest to the small pinion into the dog clutch on the layshaft. Pick up the mainshaft, which should be complete with its dog clutch, and put it in position so that the second selector fork engages with the mainshaft dog clutch. The whole assembly can now be fitted into the gearbox, the mainshaft being the first to enter its bearing. Verify again through the inspection cover that the pinions are set in the top gear position (see Fig. 35). In this position the dog

order: Ratchet, bush, ratchet pinion, spring and shouldered nut. The latter should be tightened by finger pressure only. Replace the lockwasher and note that the tongue in this washer engages with the groove machined in the mainshaft. Screw up the locknut very tightly, and tap the edge of the washer over the nut.

RE-ASSEMBLY OF THE GEARCHANGE

The ratchet sleeve plate (i.e., the plate in which there are a series of teeth) should be held in the left hand with the shortest diameter of the sleeve uppermost (see Fig. 38). One of the pawl carrier plates will be seen to have thin washer welded on to both faces, and this plate should now be superimposed upon the ratchet plate so that the pawl fits into one of the teeth adjacent to the link pin hole. Place the remaining

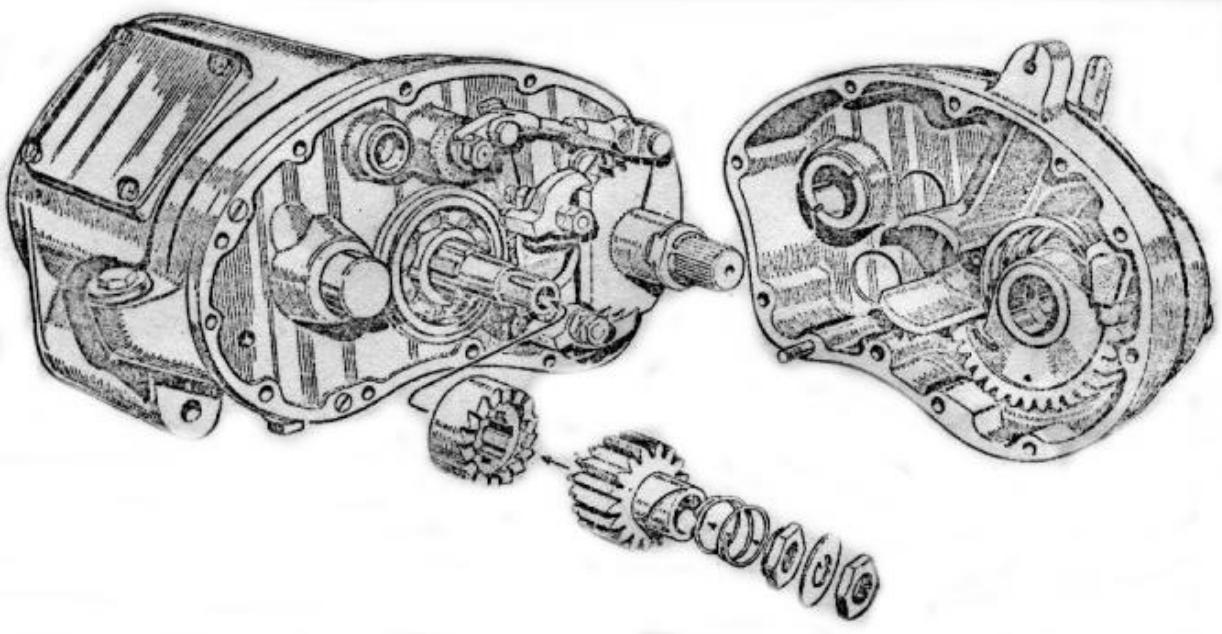

clutch on the mainshaft is in mesh with the pinion sleeve.

Replace the low gear pinion on the layshaft and if all has been assembled correctly, the face of this pinion should be just flush with its mating pinion on the mainshaft. The oil flinger washer and spacing collar can now be refitted to the mainshaft (see Fig. 35). The inner cover is next to be assembled. Set the selector quadrant in the top gear position (see Fig. 36) and replace the cover. The paper washer between the inner cover and the gearbox shell should be smeared with jointing compound before final assembly. If the cover will not fit properly at the first attempt, a **slight** movement of the selector, by means of a spanner, will cause the selector teeth to mesh properly with the selector shaft pinion and then the cover may be pressed home.

Replace the four screws and locking strip, bending the corners of the latter to suit. All shafts should have the minimum of end play, and engagement of dogs should be checked in each gear.

The ratchet mechanism may now be refitted to the mainshaft, the parts assembling in the following

pawl carrier on top of the original one so that its pawl engages with the second set of teeth on the ratchet plate.

Still holding the gearchange assembly in the left hand, take up the gearchange spindle in the right hand, holding it by the threaded end and fit it into the ratchet sleeve so that the plate fixed to the spindle lies between the spring anchor pegs. With the aid of a pair of pliers, replace the two springs and fit the circlip in position. The whole process of re-assembly of the gearchange mechanism will be made much easier by a study of the illustration (Fig. 38).

The unit is now ready for re-assembly into the gearbox. Make sure that the spring-loaded plunger is in position behind the unit before it is replaced. Couple the link arm to the ratchet plate and take care to replace the split pin. It should not be necessary to make any adjustment to the length of the link itself – this has been set when the gearbox was originally built, but if the gears will not engage properly a slight adjustment to the length of the link will be sufficient.

Before the re-assembly is carried out a stage further, loosely replace the gearchange pedal and check the operation of all gears by inspection through the cover. It will, of course, be necessary to move the gearbox sprocket by hand when endeavouring to engage the gears. When all is found to be correct, set gears in top gear position again, and remove the gearchange pedal. The clutch push rod is next to be replaced, and with this in position the small felt washer must be added. This washer is important since its function is to prevent any possibility of oil passing along the hollow mainshaft, to the clutch plates. Finally, put back the gearbox cover, carefully tighten all screws, and carefully replace the kickstarter crank and gearchange pedal. As the gearbox is still set in the top gear position when the indicator disc is replaced this also should be set to top gear.

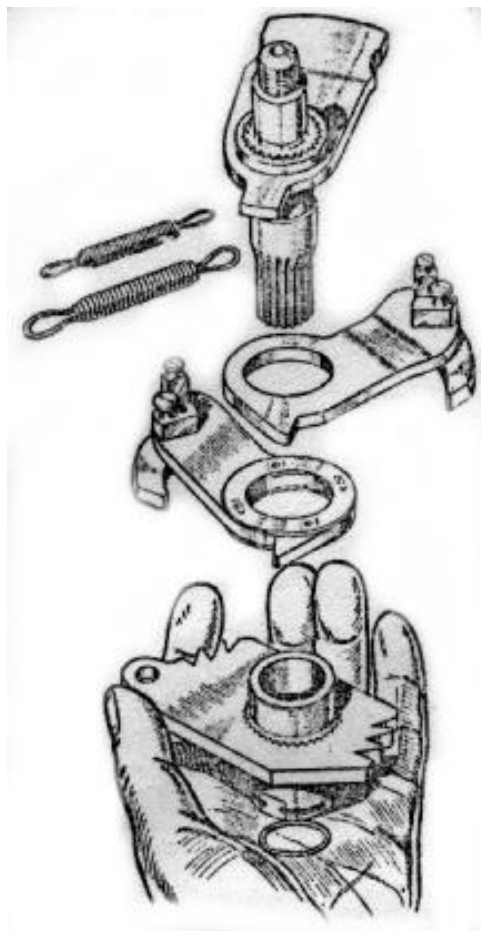

Fig. 38.
Gear change mechanism

The replacement of the gearbox should not present any difficulties. When the box is in position and the fixing bolts are about to be tightened up, make sure that the flats just below the bolt heads register properly in the slots machined in the yoke plates. Also, on the rear bolt, an adjuster is provided for tensioning the primary chain; this must be in position and the chain tension adjusted before the gearbox bolts are finally tightened. The latter must be really tight after the adjustment is made. There should be about ½ " total play in the chain (see "Front Chain", page 20). Replace the oil tank pressure release pipe together with the clutch cable and its adjuster. The inner half of the primary chaincase may now be fitted, followed by the cush drive, chain and clutch, together with its pressure plate and cover. Finally refit the outer half of the chaincase and then the footrest. The refitting of the clutch and primary chaincase is described in the chapter "Re-assembly of the Clutch" on page 22. The clutch adjustment may require setting and this should be carried out in

accordance with the instructions given on Page 20. It is also possible that the rear chain will require re-tensioning and this may be done by movement of the rear wheel (see page 20).

REPLACEMENT OF THE GEARBOX

SPECIAL INSTRUCTIONS FOR THE CLEANING AND LUBRICATION OF HUBS

Remove bearing cone assemblies from hub as described in the next section, page 27. Wash bearings, cones, spindle and inside of hub in paraffin and dry thoroughly. Do not use compressed air. Inspect bearing races and replace if damaged. Replace grease seals if necessary. Lubricate bearings with grease No. 2 with a wheel-bearing packer, or by hand, kneading lubricant into all spaces

in the bearing roller cage. Use extreme care to protect the bearings from dirt and dust. Pack inside of hub shell with grease No 2. The lubricant in the hub and bearings is sufficient to provide lubrication until the next service period. Reassemble and adjust bearings in accordance with the instructions given in the next section.

ADJUSTMENT, DISMANTLING AND RE-ASSEMBLY OF HUBS AND BRAKES

REAR HUB (Fig. 39)

The rear wheel is of the quickly detachable type and the taper roller bearings are contained in the wheel hub. To remove the rear wheel it is only necessary to undo the three retaining bolts and withdraw the spindle from the nearside. The latter is released after the nut on the offside end is removed. **The spindle does not unscrew; it is a push fit in the hub.** Should it be too tight to be removed by hand, it may be tapped out from the offside. Remove the distance piece on the right-hand side and withdraw the hub to the right from the driving studs. The wheel itself is

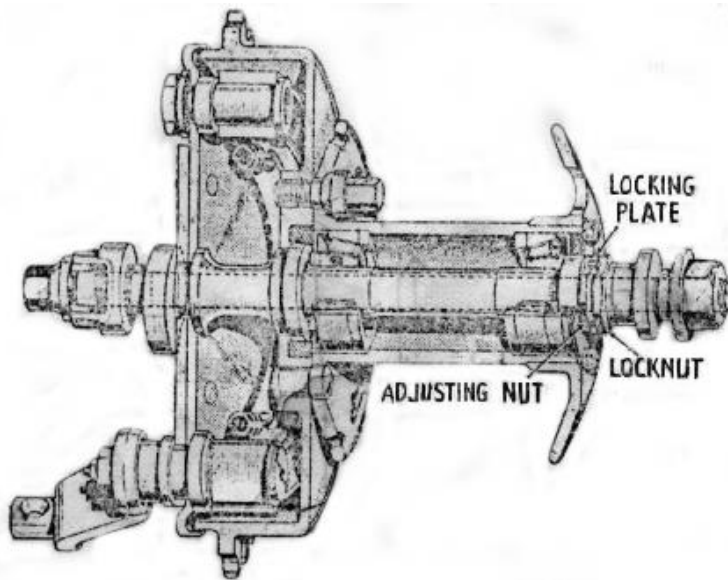

Fig. 39. Section through rear hubs.

now free and can be taken out rearwards after the detachable portion of the mudguard is removed. Uncouple the rear chain, the brake cover plate (at its junction with the torque stay) and the brake rod. The whole brake drum assembly can now be taken off, after removal of the locknut on the nearside of the spindle.

To remove the bearings it is only necessary to take off the locknut and adjusting nut on the right-hand side of the hub, when the bearing sleeve may be drawn out from the opposite side. The outer races of the bearings are lightly pressed into the hub and will tap out easily after removal of the dust-cap. Thoroughly clean the bearings and examine carefully. If they have been run in too tight a condition, flats may have been worn on the rollers and a track formed in the outer race. Check also that the bearing sleeve and hub spindle have not been distorted through misuse. If necessary, renew. The brake drum cover plate can be withdrawn from the brake drum and it will be seen to carry the brake shoes together with their fulcrum pin and operating cam. It is unlikely that these will require attention although the latter should be checked for freedom of movement and dismantled and greased if necessary. To remove the brake shoes, lay drum cover plate flat

on bench (shoes uppermost) and lever shoes upwards. They can then be drawn over and free of cam and fulcrum pin. To replace, attach springs and reverse method of removal. If the cam pads show excessive wear, new shoes should be fitted, otherwise if only the brake linings are worn these alone need be replaced.

If examination of the brake drum shows that the sprocket teeth have become hook shaped and the braking drum scored, a new drum must be fitted.

The drum must not be machined to produce a new braking surface. To do so is only a temporary cure and further attention would be required later.

When new linings, or new shoes have been fitted, the brakes must be centralised after refitting the wheel. To do this, replace the brake cover plate, complete with shoes, fulcrum pin and cam, in the brake drum. Slacken the fulcrum pin nut, and turn the cam so as to open the brake shoes in the normal manner when the fulcrum pin will move in its slot until both shoes are pressing equally on to the drum. Tighten the fulcrum pin nut firmly and release the brake.

RE-ASSEMBLY

After fitting new bearings and bearing sleeve, together with the adjusting nut, in position, make certain that there is a trace of play in the bearings. If they are locked up so that no play is apparent, rapid wear will be caused. The adjustment should be such

that the side play at the wheel rim is not more than $\frac{1}{64}$ " after the locking plate has been replaced and locknut screwed up tight.

Replace the brake assembly in position and couple up the rear chain, cover plate and brake rod. Verify that the brake cam is against its stop and adjust the chain for tension (see page 20). For this latter operation, the wheel spindle must be replaced (without the hub being in position)

Withdraw the wheel spindle and replace the wheel in position. **The wheel bolts must be screwed up tight and must be kept dead tight at all times.** Slackness will result in elongation of the stud and dowel holes in the hub flange, necessitating replacement. The spring washers fitted with these three bolts have been replaced (commencing with frame No. WDM20/82773) by chamfered bolt heads and corresponding spherical seatings in the hub. Method of tightening is to turn wheel until one of the three bolts can be seen between mudguard upright and saddle to hub backstay. Insert bar type box spanner 69-9038 through hole in hub and engage head of bolt. Place box spanner 66-9067 over squared shank of first spanner and tighten bolt as necessary. A full half turn is possible before spanners need to be

Re-positioned. Insert the wheel spindle, but before finally tightening the spindle nuts, the chain should be finally adjusted and the wheel aligned by means of the gauge provided in the tool kit (see page 21).

FRONT HUB

The particulars given above for the rear hub are essentially the same for the front hub. Before the wheel can be removed, however, the speedometer drive cable must be disconnected at its lower end, and also the front brake cable. After withdrawing the wheel from the forks remove the speedometer drive from the spindle, for which purpose, it is only necessary to unscrew its locknut. This will expose the bearing adjusting sleeve and locknut. When replacing the speedometer drive unit make sure that the tongues on the driving pinion engage with the slots in the hub shell.

BRAKE ADJUSTMENT

The front brake is adjusted by means of the screwed sleeve on the cable stop, fitted to the brake cover plate.

The rear brake is adjusted by means of a wing nut on the end of the brake rod. An adjustable stop is provided to enable the pedal to be altered to suit the rider's convenience.

BRAKE RELINING

After removal of the brake shoes (see "Dismantling the Hubs", page 27) the old lining is easily taken off

by gripping the shoe in a vice, inserting a chisel under one end and shearing the rivets off in sequence. The rivet ends can then be punched out of the shoe.

New linings are die-pressed to suit the curvature of the shoes, but will require drilling and counterboring to take rivets. Position the lining and hold it in place at one end by means of clamps. Using the holes in the shoe as guides, drill holes of the correct size (5/32" dia) for the rivets adjacent to the clamp. Turning the shoe over, counterbore the holes just drilled, sufficiently deep so that the rivet heads will stand below the lining surface; this is important, since the rivets will otherwise score the brake drum. Insert rivets into the holes and rivet them over on the inside of the shoe. This is easily accomplished by holding in a vice a short length of rod, whose diameter is equal to that of the rivet head, and using it as an anvil upon which to rest the rivet head while hammering the shank over. This will also make sure that the rivets do not stand proud of the lining. Move the clamps to the next pair of holes, taking care that the lining is kept in firm contact with the shoe the whole time, and repeat the above procedure. When the lining is finally riveted down, bevel of the ends of the linings and file off any local high spots. Precautions to be observed when fitting the relined shoes to the hubs are given in the chapter on "Dismantling the Hubs", page 27.

ADJUSTMENTS TO STEERING HEAD AND FRONT FORKS

STEERING HEAD

In order to feel any play in the steering head the front wheel must be clear of the ground, so that a box of suitable dimensions should be placed under the engine. Loosen the head yoke clip nut (just below the handlebars) and tighten the sleeve nut on top of the steering column until there is no perceptible shake in the head.

Do not adjust too tightly, otherwise the ballrace will be damaged and the steering will become stiff. Lastly, tighten the clip nut.

If a steering damper is fitted it is necessary to remove the knob before the adjusting sleeve is tightened.

FORK LINKS (Fig. 40)

The link bolts must be just tight enough to prevent side play. First, slacken off the shock absorber on the lower fork link, then release the locknuts on the offside of the links, screw up the bolts from the nearside and retighten the nuts.

FORK DAMPER.

This must, of course, be adjusted by the rider to suit road conditions, and the thumb wheel can be reached from the saddle. On earlier models, instead of the thumb wheel, there is a large nut, for which spanner adjustment is necessary, and consequently cannot be

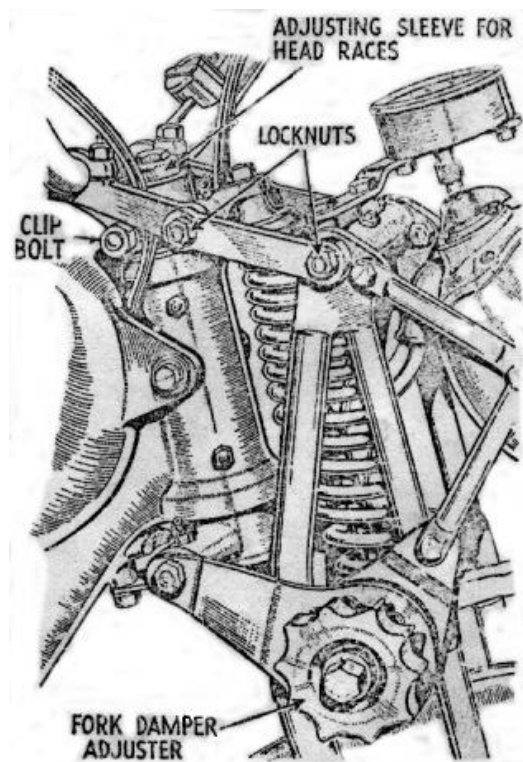

Fig. 40. Fork links and steering head.

REMOVAL AND DISMANTLING OF FRONT FORKS AND STEERING HEAD

There is no necessity to disturb the electrical system as a whole, when removing the forks. The instrument panel on the back of the headlamp is retained by three screws, and if these are removed, the panel is released and the wiring can be withdrawn through the aperture after releasing the four connections (see Fig. 41). Place a box under the engine so that the front wheel is clear of the ground.

Remove the nut from the fork spring top scroll, then remove both top fork links and prise scroll downwards until the bolt is free from the headlug. Headlamp wiring should now be drawn out at the side of the forks.

To take off the fork spring it is only necessary to unwind the spring from its bottom scroll. If difficulty is experienced place a piece of rod against end of spring and give a sharp blow with a hammer. Disconnect the front brake cable, remove the two lower fork links, and the whole front fork assembly can be taken off complete with speedometer, headlamp and front wheel.

Dismantling the steering column is quite straightforward. Take off the steering damper knob (if fitted) and slacken the head yoke clip nut (just below the handlebars). Remove the sleeve nut on top of the column and uncouple the steering damper plates at the frame lug.

The steering stem can now be driven out (downwards) with a lead hammer to prevent damage to the threads. The stem will bring with it the lower ballrace cone, leaving the cups in position at the top

opposite end of the head lug, and the extractor and ballrace driven out together.

If the balance cups and cones are pitted, to even a slight degree, they must be replaced, otherwise the steering will be uncomfortable. Note that the pitting is invariably due to "hammering" of the balls in their tracks, due to slack adjustment in the first place.



Fig. 42. Steering head ballrace extractor.

RE-ASSEMBLY

When fitting new ballrace cups make sure they are driven in squarely and that they are pressed well home. Replace the steering stem and if any difficulty is experienced in making the balls (of which there are 20 top and 20 bottom – all $\frac{1}{4}$ ") stay in position, the tracks should be heavily smeared with grease. Refit the dust cover and steering head yoke, followed by the top sleeve nut. The latter may now be tightened, until there is no trace of play in the head. On the other hand, do not tighten excessively. Replace the steering damper rod, complete with plates, from below and tighten the damper plate securely to the frame. The lower end of the steering damper rod is slotted to take the fork link bolt, and care must be taken to see that the rod is fitted so that the link bolt can slide through.

The fork spring should be carefully inspected. If it is suspected as having been weak through prolonged use over bad roads, or shows signs of collapse, a new one should be fitted. Attach the spring to its bottom scroll, and replace the bottom two fork links loosely in position. Refit the top scroll in position, draw the wiring to the headlamp forward to its normal position, and assemble the top fork links. Adjustment of the links should be such that there is no side play present. The headlamp connections are shown in Fig. 41.

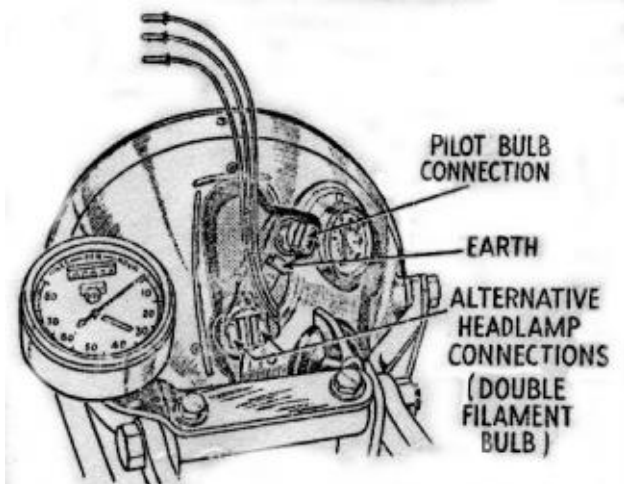

Fig. 41. Headlamp connections.

and bottom of the steering head. A simple extractor shown in Fig. 42 is used for the removal of these cups. They are threaded to take the extractor, which should be screwed well home, since it engages with a few threads only. A bar is then inserted from the

29 CHAIN ALTERATIONS AND REPAIRS

A chain rarely breaks if it is kept properly lubricated and adjusted. Usually it is worn out long before it reaches breaking point. The rear chain is the most heavily stressed and is therefore the one most likely to give trouble. Spare parts are carried to enable the rider to carry out a repair on the road with the aid of a chain rivet extractor (see Fig. 43). The front chain will probably be worn out before it requires shortening.

HOW TO USE THE CHAIN RIVET EXTRACTOR

First press down lever A (Fig. 43) to open the two jaws (B). Insert the link to be removed so that the jaws grip the roller and support the uppermost inner side plate. The Punch (C) is then screwed down on to the rivet head until the rivet is forced through the outer plate.

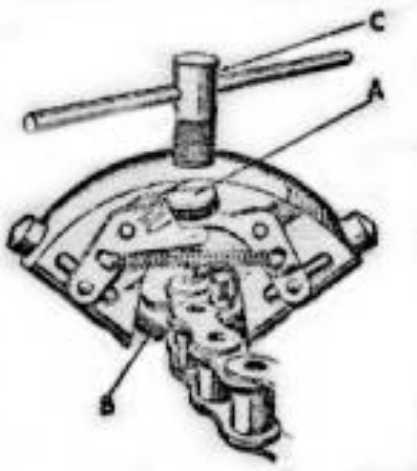

Fig. 43.

TO SHORTEN A WORN REAR CHAIN

After a big mileage, the rear chain may have stretched so that no further adjustment is possible by the usual method (described on page 20). In this case it is possible to shorten the chain by one link or pitch, so increasing its useful life. First remove the single connecting spring link (A) securing the two ends of the chain (Fig. 44). If the chain terminates in

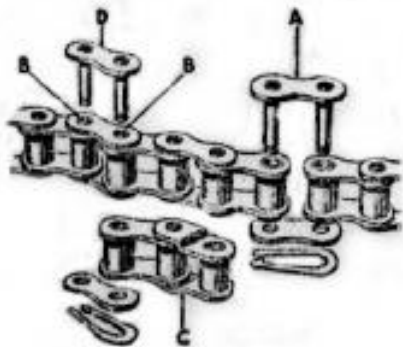

Fig. 44.

two ordinary links as in Fig. 44 (in which case the chain will be of an even number of pitches) extract the third and fourth rivets (B) from the end and replace the detached three pitches by a single

connecting link (C). The connection is made with an additional spring link (D). If one end of the chain has a double cranked link (Fig. 45) – in which case the chain will have an odd number of pitches – extract the second and third rivets (A), releasing the cranked link unit complete, which can be retained for future use. Replace the one inner link (B) and again connect up with an additional single connecting link (C).

TO REPAIR A DAMAGED CHAIN

If a roller or link has been damaged (X, Fig. 45) remove rivets (D), take out the damaged link and replace with one inner link, secured by two single connecting links.

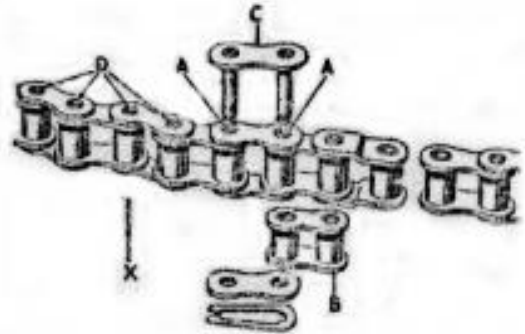

Fig. 45.

It is important that the spring clip fastener should always be put on so that the CLOSED end faces the direction of travel of the chain – i.e., when the clip is on top run of chain closed end is towards front of machine – when clip is on bottom run, closed end is towards rear of machine.

It should be noted that once a rivet has been extracted it must not be used again, so that it is important to check that the correct rivet is being removed before actually removing it. In the case of double cranked links, the complete unit comprises an inner link and the cranked outer link – three rollers in all – and these must never be separated.

FITTING REAR CHAIN

To fit a new rear chain, turn wheel until the spring link of the old chain is located on rear sprocket. Disconnect and allow the lower run to drop down. Join the top run of the old chain to the new chain by means of the connecting link, and then by pulling on the bottom run of the old chain the new one will be carried around gearbox sprocket. Then the old chain can be disconnected and the ends of the new one joined together.

When the rear chain breaks and falls from its sprockets, the new or repaired chain can be replaced without taking off chainguards. One end of the chain must be fed (from the rear) under the front end of the rear top chainguard on to the gearbox sprocket. A long bladed screwdriver or a piece of stiff wire may assist this operation. When

the chain has located on the sprocket teeth, engage a gear and gently turn gearbox over with the kickstarter. This will feed chain round gearbox sprocket. When sufficient length of chain is hanging below sprocket, disengage gear and chain can then be pulled round until both runs can be fed inside rear chainguard and engaged on rear wheel sprocket.

HOW TO MEASURE WEAR IN A MOTOR CYCLE CHAIN.

First carefully clean off all oil, etc., from the bearing surfaces of the joints, i.e., from the bush bores and bearing pins. Next, place the chain on a flat surface and exert a pull on the ends. (Actually measurement should be made under a load of 28lb. For .5in. pitch, or 44lb. For .625in. pitch chain, but a sufficiently accurate measurement can be obtained providing the chain is pulled enough to take up all joint clearances).

Having extended the chain to its maximum, measure the distance between the bearing pin centres over a

pre-determined length; the measurement so obtained can then be compared with the nominal length, the difference being, the amount of wear that has taken place. For example, if it is decided to measure the distance over 20 pitches of a .5in. pitch chain, the measurement should normally be 10in. If in the case of the worn chain the same number of pitches measure 10.20in. the elongation is of course .20in. This amount, expressed on a percentage basis is:

$$\frac{.20}{10} \times 100 = 2.0\%$$

It is possible to measure the whole chain, but it is preferable to measure successive sections as this will show whether wear is varied or equally distributed. If the whole chain or any section shows the equivalent of 2.0% wear the chain should be replaced. It is incorrect to try to measure chain wear by checking the difference in length when the chain is pushed together against its length when pulled out, as this makes no allowance for the small clearances which are present even in a new chain.

THE ELECTRICAL EQUIPMENT THE WIRING SYSTEM

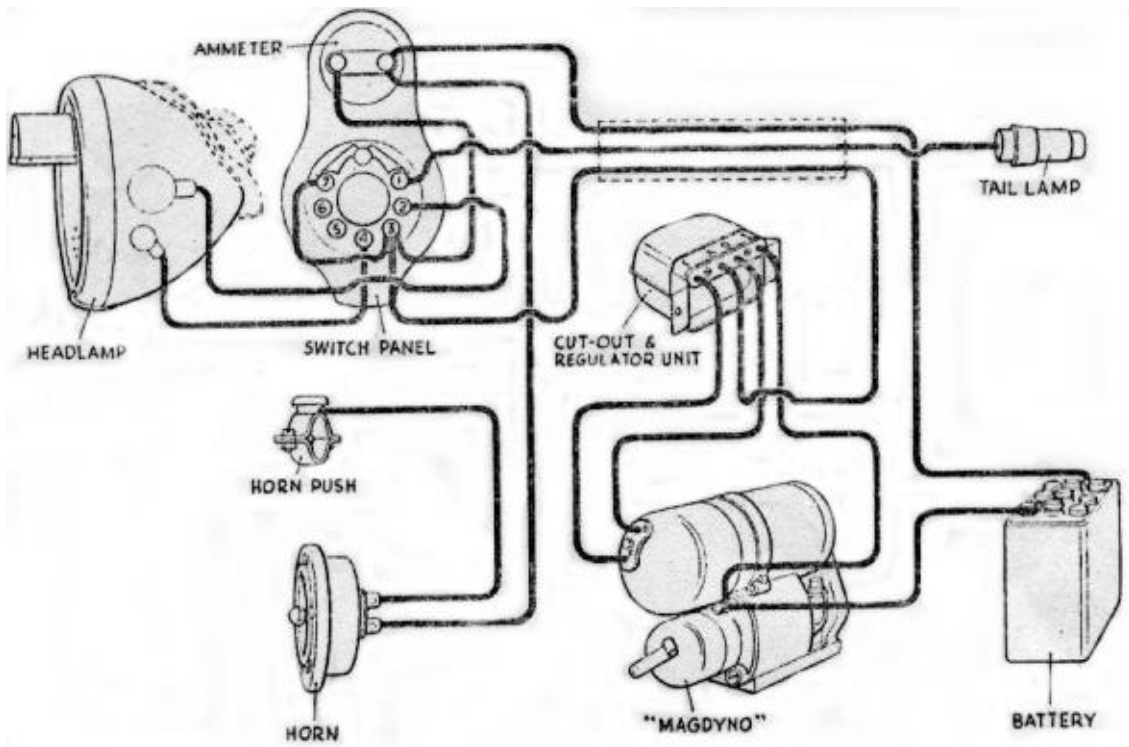

Fig 46A. Simple wiring diagram for models fitted with ammeter.

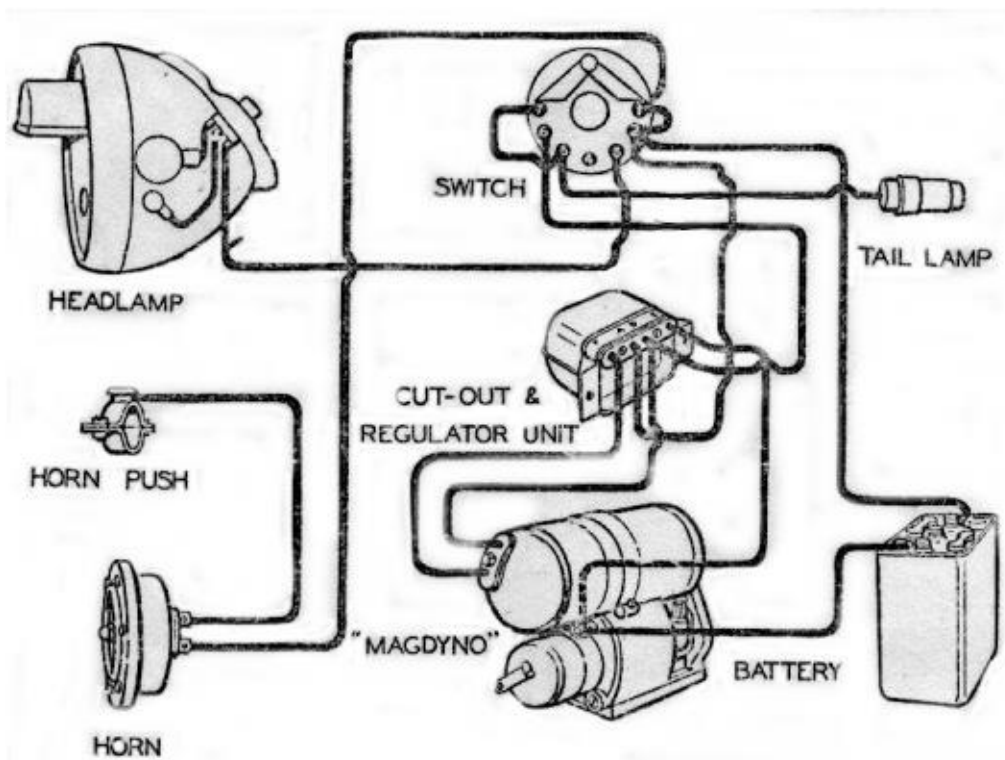

Fig 46B. Simple wiring diagram for models fitted without ammeter.

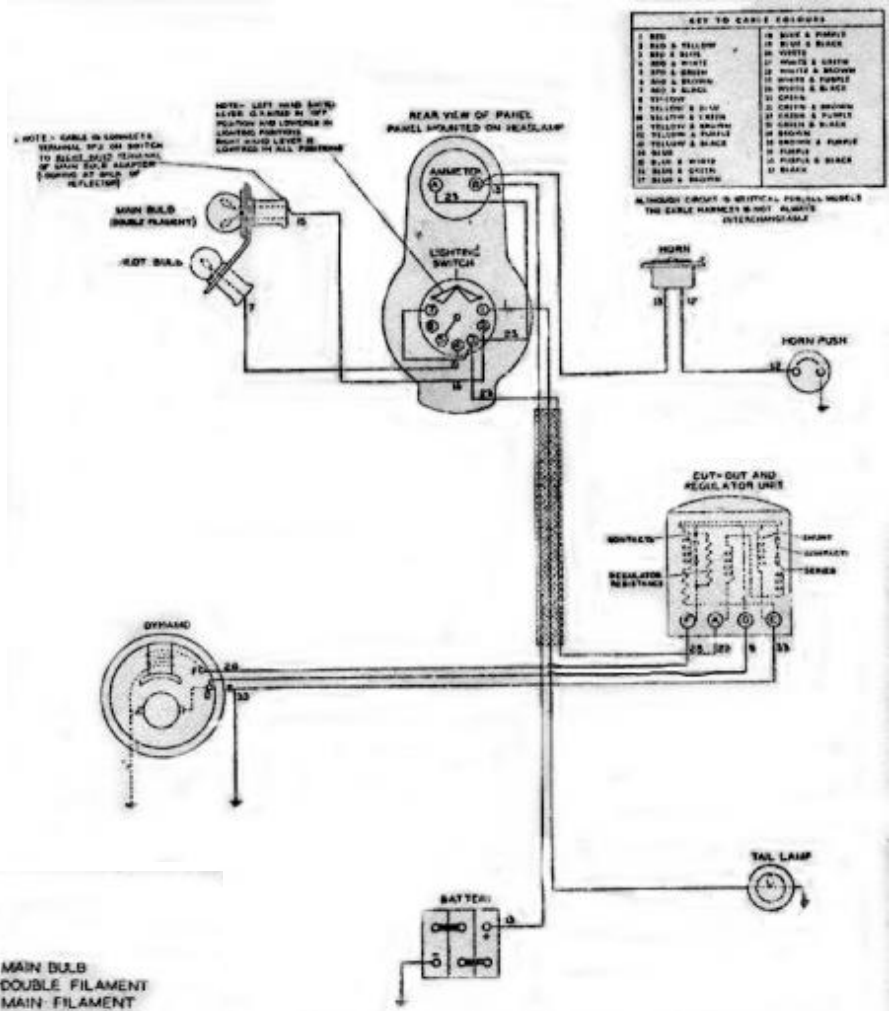

Fig. 46C. Wiring diagram in models fitted with ammeter.

The Wiring System

In the event of the wiring system requiring replacement, no difficulty should be experienced provided that the diagrams (Figs 46A, B, C and D) are carefully followed. It should be noted that Figs 46A and C apply only to machines on which an ammeter is fitted. Figs 46B and D apply only to later models with a push switch in headlamp and no ammeter.

The cables from the headlamp and horn are grouped together in a harness, which is clipped to the frame top member, and in order to gain access to this fixing, the petrol tank must be removed. There is no need to drain it. Set the taps in the "off" position, uncouple the petrol pipes and release the front and rear tank mountings, when the tank can be taken off.

The connections to the regulator, mounted on the rear mudguard below the saddle, will be much easier of access if the regulator itself is first released from the guard.

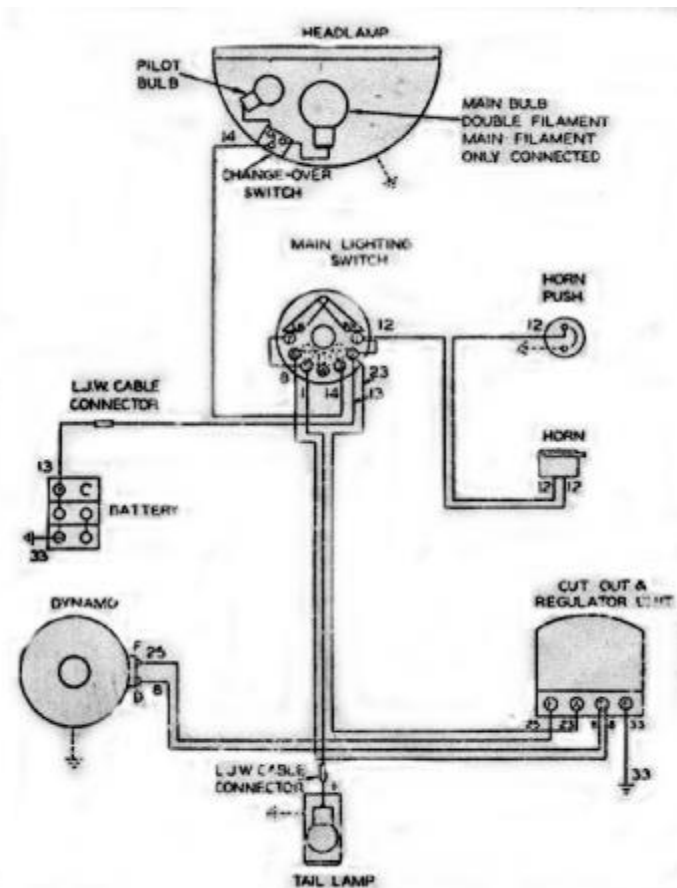

Fig. 46D Wiring diagram for models without ammeter.

IGNITION (Section A)

A(1) "MAGDYNO" TYPE M01 A(2) Magneto Routine Maintenance

Lubrication

The cam is lubricated by a wick, contained in the contact breaker case, which must be given a few drops of thin machine oil about every 2,000 miles. To get at the wick, remove the spring arm (A, Fig. 47) carrying the moving contact and withdraw the screw (B) carrying the wick. At the same time after

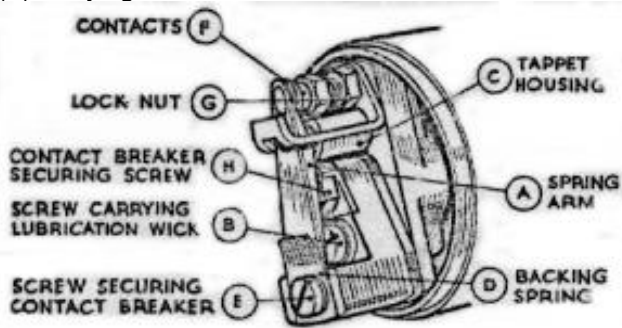

Fig. 47. Contact breaker with cover removed.

unscrewing (H) remove contact breaker and take from its housing (C) the tappet which operates the contact breaker spring and lightly smear with thin machine oil. When replacing the contact breaker components, see that the small backing spring (D) is fitted immediately under the adjusting screw (E) and spring washer and that the bent portion faces outwards.

Adjustment.

After dismantling the contact breaker in order to lubricate, the contact setting should be checked. Turn the engine until the contacts (F) are fully opened and insert the gauge provided (.010" - .012" thickness) between the contacts. If the setting is correct, the gauge should be a sliding fit. If there is an appreciable variation from the gauge, slacken the locknut (G) and turn the contact screw by its hexagon head, until the gap is set to the gauge. Tighten the locknut after making the adjustment.

A(3) MAGNETO – Testing in position to locate cause of misfiring or failure of ignition.

Disconnect the cable from the sparking plug and hold the end about 1/8 " from some part of the cylinder block while the engine is turned over. If the sparking is strong and regular the fault lies in the sparking plug which must be removed for examination and if necessary cleaned and adjusted.

Next examine the high-tension cable. After long service, it may have become cracked or perished and the magneto may be sparking through the insulation to a metal part of the engine or frame. Correct by replacing the cable.

If the performance of the magneto is still unsatisfactory, the contact breaker may require cleaning or adjustment (see paragraph A (2)) or there

may be an internal fault in the magneto. The following procedure should, therefore, be adopted.

A (4) Magneto Contact Breaker – Cleaning

Remove the contact breaker cover and examine the contacts. If they are dirty, they must be cleaned by polishing with a very fine carborundum stone or very fine emery cloth; afterwards wipe away any dirt or metal dust with a petrol moistened cloth. Cleaning of the contacts is made easier if the spring arm carrying the moving contact is removed as described in paragraph A (2). Examine the spring arm of the contact breaker and wipe away any rust. Adjust as described in paragraph A (2).

A (5) H.T. Cable

Should be 7mm in diameter. Other sizes such as 5mm and 9mm will not fit in the immobiliser and suppressor. The cable must be replaced if the rubber insulation has perished or shows cracks and becomes brittle. To fit the new cable to the pick-up terminal (Fig. 48) thread the knurled moulded nut (A) over the lead (B), bare the cable for about 1/4 ", thread the wire through the metal washer (C) removed from the old cable and bend back the strands (D). Finally, screw the nut into its terminal.

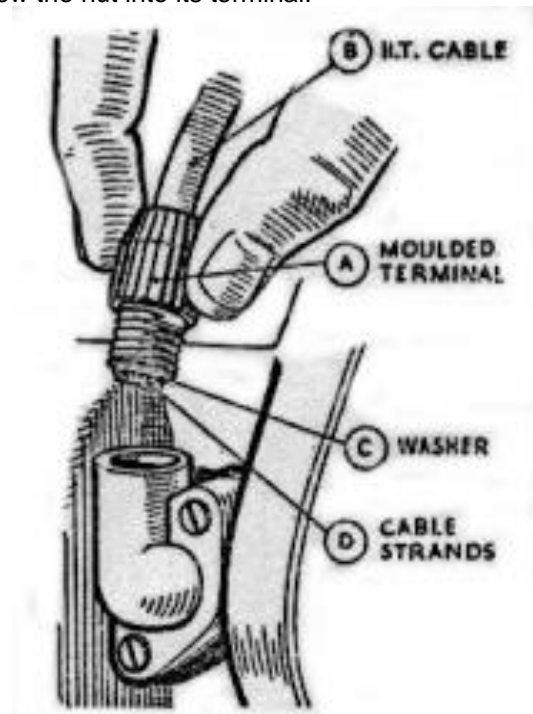

Fig. 48. Pick-up terminal.

A (6) Pick-up

Examine the pick-up or high tension terminal (A, Fig. 51). See that the carbon brush (B) moves freely in its holder, being careful not to stretch the brush spring unduly. While the pick-up is removed, clean the slip ring track and flanges (D) by holding a soft cloth on the ring while the engine is slowly turned by means of the kickstart. When replacing the pick-up, do not forget to fit the cork gasket (C).

A (7) Resistor and Immobiliser

Check for cracks in the insulation and for positive contacts of the high tension cable; always disconnect lead at sparking plug before unscrewing immobilisers.

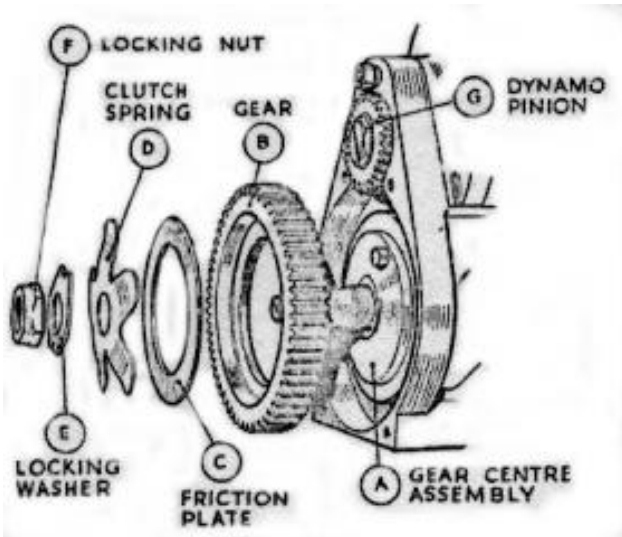

Fig. 49. Exploded view of components of the Slipping clutch.

A (8) Sparking Plug.

Clean the sparking plug by removing carbon or oil from the electrodes with a wire brush or dismantle the plug and wash in petrol. Adjust the electrodes to give a gap setting of .020" - .025".

A (9) Magneto Slipping Clutch (see Fig. 49).

Description

A shock absorbing drive is incorporated in the larger of the two gears, which take the drive from the magneto shaft to the dynamo. This considerably relieves the peak loading on the teeth of the driving gear and gives a far longer life. The drive is taken from the gear centre (A), which is keyed to the magneto shaft, through the fabric gear (B), which is

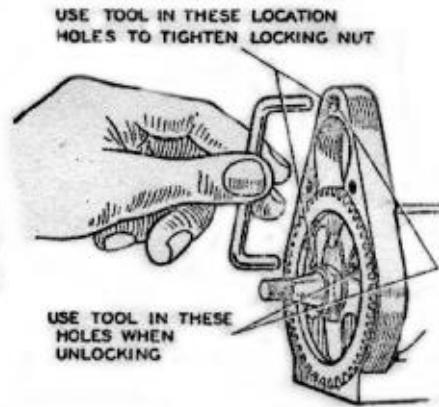

Fig. 50. Slipping clutch showing the jig to lock the large gear.

held against the gear centre under the pressure of the star shaped spring (D) to the pinion (G) on the dynamo shaft. The effect of a violent overload is to cause the fabric gear to slip relative to the gear centre and so prevents shock from being transmitted to the fabric gear.

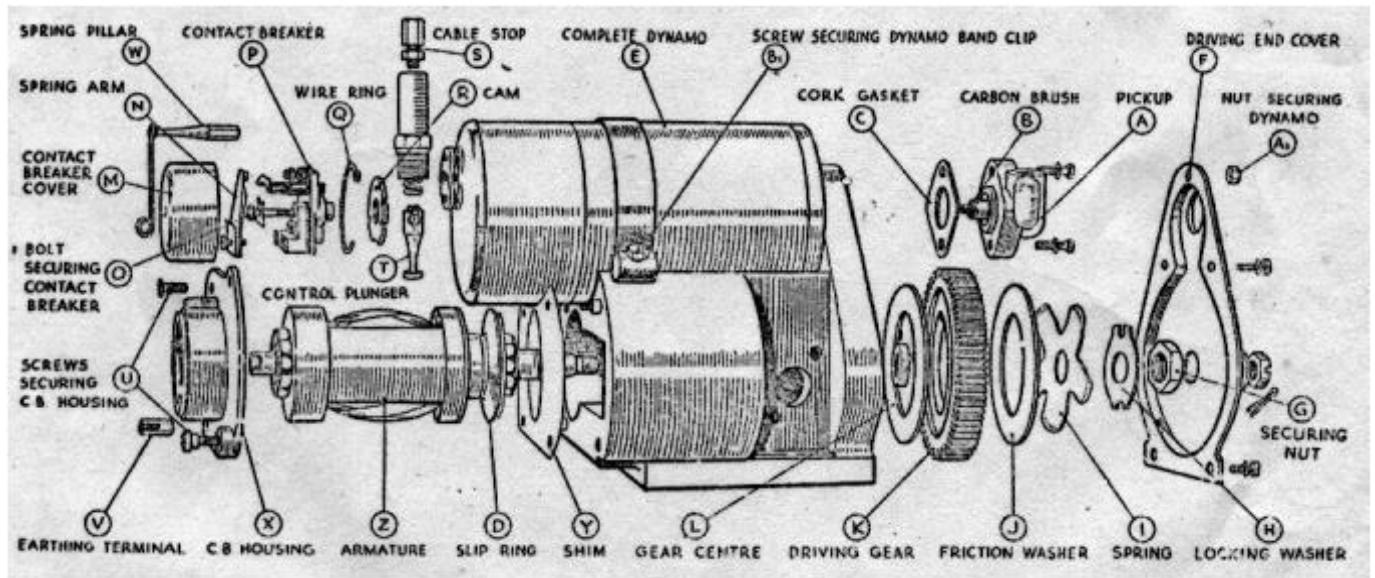

Fig. 51. Exploded view of magneto portion of dynamo.

A (10) Removal from engine

Before the magdyno can be removed from the engine, it is first necessary to take off the timing cover. With this removed, the magdyno pinion must next be withdrawn from the shaft by means of the extractor shown in Fig. 10. There is a special oil seal washer fitted behind the pinion – see that this is not lost. Now release the straps holding the magdyno on its platform, and the whole instrument can be lifted off.

Retain any shims which may have been fitted under the base and replace when refitting magdyno.

A (11) Magneto dismantling.

Remove the dynamo (E, Fig. 51) and take off the driving end cover (F) by unscrewing the four countersunk head screws. To dismantle the slipping clutch it will be necessary to use a jig (Fig. 50) to hold the larger gear whilst the securing nut is being undone. This consists simply of a length of $\frac{1}{4}$ " diameter mild steel rod bent to a flat U, the ends being cut short with their centres $3\frac{3}{16}$ " apart, so that one can be slipped in the hole in the wheel while the other is engaged with the hole in the top of the casting through which the dynamo securing stud usually goes. The $\frac{7}{16}$ " box spanner can then be used on the securing nut (G, Fig. 51) which unscrews in the normal left-hand direction. Note that the tab of the locking washer (H) must be bent back first. Remove the locking washer (H), clutch spring (I), friction washer (J), driving gear (K) and gear centre (L).

A (12) Magneto Armature – Removing.

Take off the contact breaker cover (M), remove the spring arm (N) carrying the contact, unscrew the bolt (O) securing the contact breaker (P) and draw the

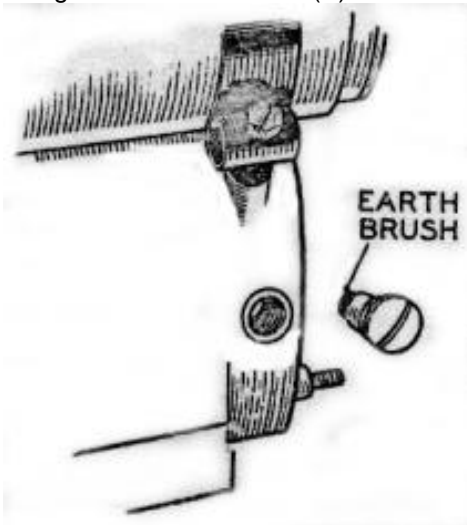

Fig. 52. Magneto earthing brush.

contact breaker off the shaft. Spring the wire ring (Q), securing the cam (R), out of its location in the contact breaker housing and remove the cam. Unscrew the cable stop (S) of the timing control and remove the control plunger (T). Remove the pick-up holder and the small earthing brush (Fig. 52) which will be found on the side of the magdyno. Unscrew

the screws (U, Fig. 51), earthing terminal (V), and pillar (W) from the contact breaker end plate (X) and remove the plate from the magdyno, together with shims (Y). The armature (Z) can then be drawn out of the machine. There is no need to put a keeper

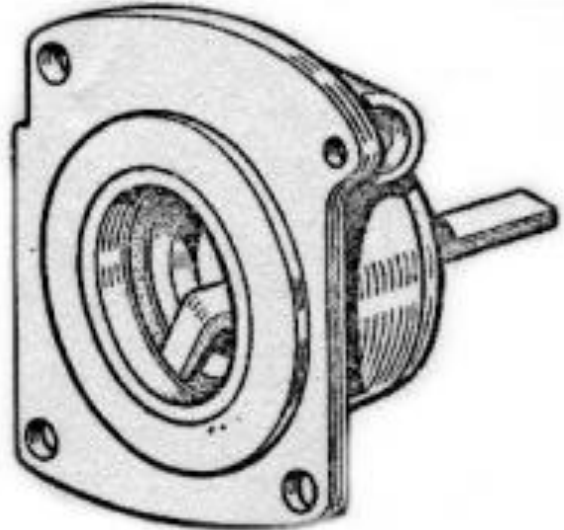

Fig. 53. Method of removing outer journals of bearings.

across the magnet as it retains its magnetic properties more or less indefinitely. Although it loses a certain immaterial amount of power in the first removal of the armature, subsequent removals do not affect it. Do not allow the magneto body to become in close contact with any iron filings as they may become attracted to the magnet and cause the armature to bind.

The ballraces can be removed from the magneto armature shaft by means of an extractor, while a tool of the type shown should be used to remove the outer journals (Fig. 53).

A (13) Magneto Armature Testing.

If test apparatus is not available, a rough check of the armature windings can be made by means of a two volt battery (a tapping across one cell of the motor cycle battery), and an ammeter. Screw the contact breaker retaining screw (O, Fig. 51) into the end of the armature shaft. Connect one terminal of the battery, with the ammeter in series, to the screw. Connect the other battery terminal to the metal body of the armature. The ammeter will then record the current taken by the primary winding – this should be approximately four amperes. To check the secondary winding of the armature, wrap the bared end of a length of H.T. cable round the brass insert of the slip ring and hold the other about one-eighth from the armature core. If the lead from the battery which was connected to the core is then flashed quickly on and off the core, a spark should occur between the H.T. cable and the core.

No spark at these points indicates a fault either in the armature windings or in the condenser and a replacement armature must be fitted.

A (14) Re-assembling.

Wash the bearings in petrol, dry thoroughly and repack with high melting point grease. Fit ball races on armature shaft by means of a hand press and use

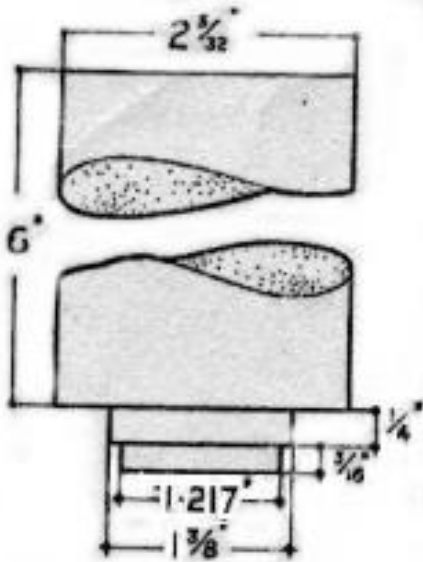

Fig. 54. Tool for fitting outer journals of bearings.

a mandrel of the type illustrated in Fig. 54 to fit the outer journals. The serrated fibre washer must be fitted behind the journal. This is provided to insulate the bearing and so prevent the electric current, which would destroy the lubricant and damage the bearing, from passing through the bearing. Place the armature in the body of the magneto and refit the contact breaker and plate, taking care that the end shims are in position and tighten the securing screws. Check the armature for end play. The

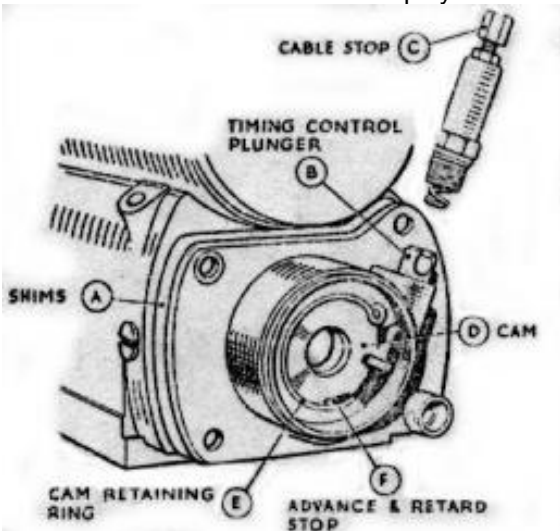

Fig. 55. Magneto contact breaker end showing fitting of cam, timing control and shims.

armature should revolve freely when turned by hand but no end play should be felt. Adjust by adding or removing shims (A, Fig. 55) and spring and secure by tightening the cable stop (C). Locate the cam (D) in the contact breaker housing with the timing control plunger in its correct slot as shown in Fig. 55 and secure by springing the circlip (E) into its location in

the housing. (Note that the cam is fitted with its flat side towards the armature).

Fit the contact breaker body (A, Fig. 56) in position on the location at the end of the shaft after making sure that the tappet (B) is free and is located correctly in its guides. Place the contact breaker securing screw (C) and locking plate (D) in position, tighten and lock by bending up the tags of the locking plate.

Refit the spring contact arm (E) with the backing spring (F) in its correct position i.e., with the bent portion facing outwards. Check the contact breaker gap and if necessary adjust to correct setting.

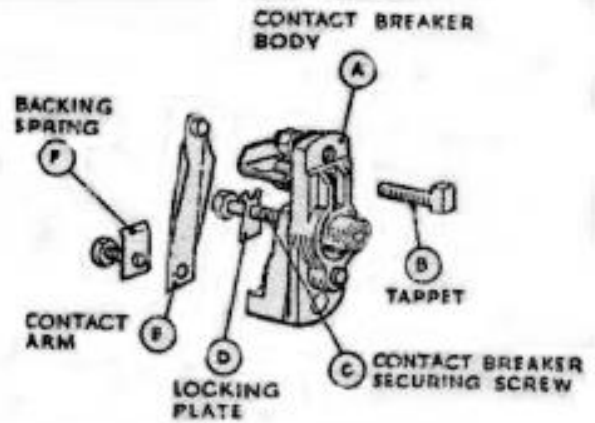

Fig. 56. Contact breaker assembly.

A (15) Re-assembling and Testing Slipping Clutch

Key the gear centre (A, Fig. 49) on to the spindle, replace the driving gear (B), friction washer (C), clutch spring (D), locking washer (E) and secure by tightening the fixing nut (F). The U shaped jig (Fig. 50) must be used to prevent rotation of the shaft while tightening the nut. After assembling, the setting of the clutch must be checked. This can easily be done by locking the driving gear and applying a

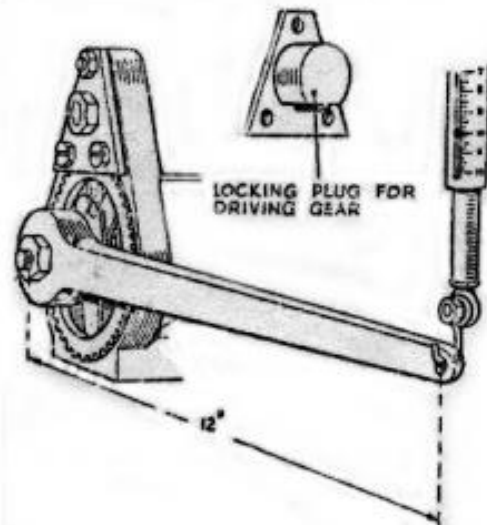

Fig. 57. Method of checking clutch setting

steady load on the driving spindle, as shown in Fig. 57. The clutch should slip with a load of 4-10 lbs. feet, i.e., a 4-10 lb. pull measured out on a spring balance via a spanner one foot long.

After setting, by slackening or tightening the securing nut (F, Fig 49) prevent further movement by bending up the tab of the lock washer (E). Refit the dynamo and pack the gears with high melting point grease. Secure the drive end cover in position with the gasket

correctly located between the cover and the end of the magdyno.

Replace the pick-up, first checking that the brush moves freely and that the cork gasket is free from cracks.

Refit the earthing brush (Fig 52).

CHARGING (Section B)

DYNAMO TYPE E3HM

B (1) Dynamo Testing in Position

- (a) Check that the Dynamo and regulator unit are wired correctly. The dynamo terminal "D" should be connected to the regulator unit terminal "D" and dynamo terminal "F" to the regulator unit terminal "F".
- (b) Remove the cables from the dynamo terminals "D" and "F" and connect the two terminals with a short length of wire.
- (c) Start the engine and set to run at normal idling speed.

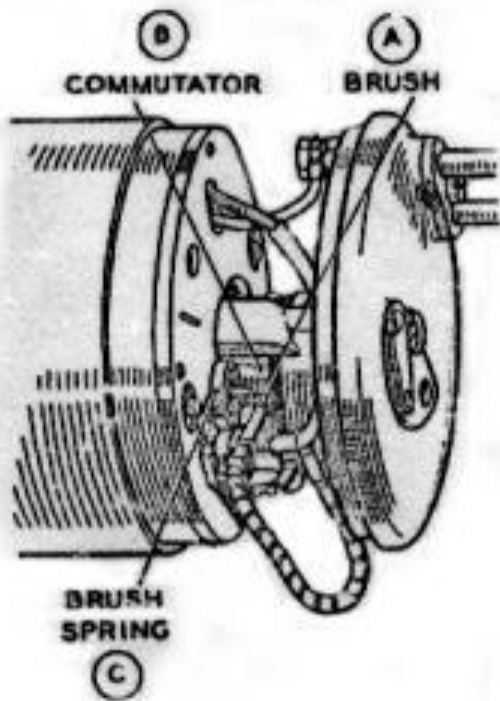

Fig. 58. Dynamo with cover band removed to show brush gear.

- (d) Connect the positive lead of a moving coil voltmeter calibrated not less than 1-10 Volts to one of the dynamo terminals and connect the negative lead to a good earthing point on the dynamo yoke or engine.
- (e) Gradually increase the engine speed, when the voltmeter reading should rise rapidly and without fluctuation. Do not allow the voltmeter reading to rise above 10 volts. Do not race the engine in an attempt to increase the voltage. It is sufficient to run the

dynamo up to a speed of 1,000 rpm. If there is no reading, check the brush gear as described in paragraph 1 (f). If there is a low reading of approximately $\frac{1}{2}$ Volt, the field winding may be at fault. If there is a reading of approximately 1 $\frac{1}{2}$ to 2 Volts, the armature winding may be at fault.

(f) Remove the dynamo cover band and examine the brushes (A, Fig 58) and commutator (B). Hold back each of the brush springs (C) and move the brush by pulling gently on its flexible connector. If the movement is sluggish, remove the brush from its holder and ease the sides by lightly polishing on a smooth file. Always replace brushes in their original positions. If the brushes are worn so that they do not bear on the commutator, or if the brush flexible is exposed on the running face, new brushes must be fitted.

If the commutator is blackened or dirty, clean it by holding a petrol moistened cloth against it while the engine is turned slowly by means of the kickstart. Retest the dynamo; if there is still no reading on the voltmeter, there is an internal fault and the complete unit, if a spare is available, should be replaced – see paragraph B (2).

(g) If the dynamo is in good order, restore the original connections to the dynamo. Connect regulator unit terminal "D" to dynamo terminal "D" and regulator terminal "F" to dynamo terminal "F". Remove the lead from the "D" terminal on the regulator unit and connect the voltmeter between this cable and an earthing point on the engine. Run the cable as before. The reading should be the same as that measured directly at the dynamo. No reading indicates a break in the cable to the dynamo. If the reading is correct, test the regulator unit – see paragraph B (11), page 41.

B (2) Dynamo To remove and replace.

Take off the connections from the dynamo terminals, unscrew the hexagon headed nut (A1, Fig 51) from the driving end cover of the magdyno, slacken the two screws (B1, Fig 51) securing the band clip and draw the dynamo out of its mounting.

When replacing, slide the dynamo through the band clip so that fixing screw (A, Fig 59) passes through its hole in the end cover and the gears mesh correctly. Tighten the end nut and the band clip fixing screws and remake the connections to the dynamo terminals

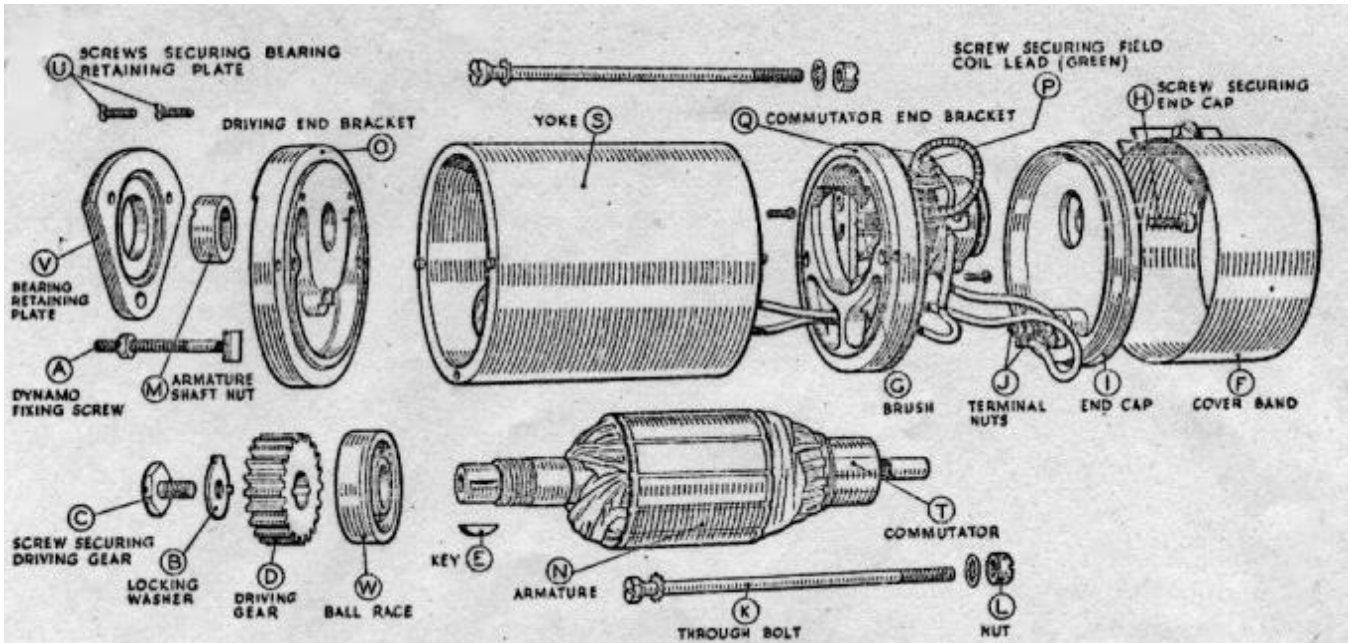

Fig. 59. Exploded view of dynamo

B (3) Dynamo – Dismantling

- (a) Bend back the tag on the washer (B, Fig. 59) locking the screw (C) securing the driving gear (D) and remove the screw. Withdraw the gear from the dynamo shaft by carefully levering it off by means of an extractor. Remove the key (E) from the shaft.
- (b) Remove the cover band (F), hold back the brush spring and lift the brushes (G) from their holders.
- (c) Take the screw (H), with spring washer, from the centre of the black moulded end cap (I). Draw the cap away from the end bracket, take off nuts (J) and spring washers, and lift the connections off the terminals.
- (d) Unscrew and remove from the driving end bracket, the two bolts (K) securing the driving end bracket (O) and commutator end bracket (Q) to the dynamo yoke (S). Hold the nuts (L) at the commutator end whilst unscrewing the bolts, and take care not to lose the nuts.
- (e) Draw the armature (N) complete with end bracket (O) out of the yoke.
- (f) Unscrew the nut (M) from the driving end of the dynamo shaft and remove the armature from the end bracket, using a hide or wooden mallet.
- (g) Take out the screw (P) securing the green field coil lead (green) to commutator end bracket and remove the end bracket (O), withdrawing the connectors through the slot in the insulating plate.

B (4) Dynamo Brushes.

Test if brushes are sticking. Clean with petrol and if necessary ease the sides by lightly polishing on a smooth file. Replace brushes in their original positions. Test the brush springs with a spring scale (Fig. 60) if available. The correct tension is 10-15ozs. Fit a new spring if tension is low. If the brushes are worn so that the flexible is exposed on the running face, new brushes must be fitted. Brushes are pre-

formed so that bedding to the commutator is unnecessary.

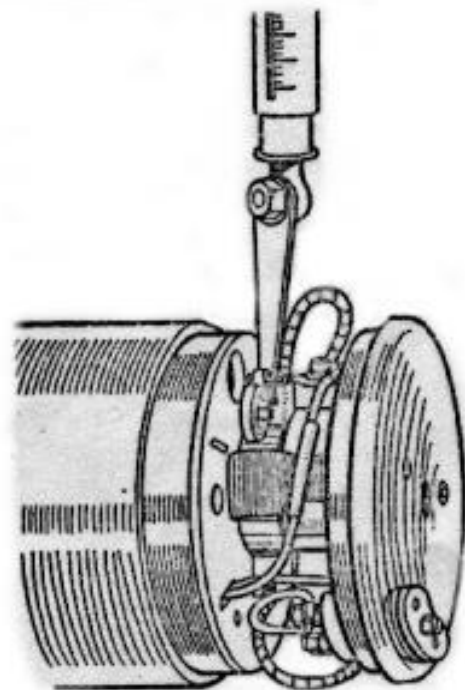

Fig. 60. Method of measuring brush spring tension.

Dynamo - Commutator

A commutator in good condition will be smooth and free from pits or burned spots. Clean the commutator with a petrol moistened cloth. If this is ineffective, carefully polish with a strip of very fine glass paper while rotating the armature. To remedy a badly worn commutator, mount the armature with or without the drive end bracket in a lathe, rotate at high speed and take a light cut with a very sharp tool. Do not remove more metal than is necessary. Polish the commutator with very fine glass paper.

Undercut the mica insulation between the segments to a depth of 1/32" (fig. 61) with a hacksaw blade ground down until it is only slightly thicker than the mica.

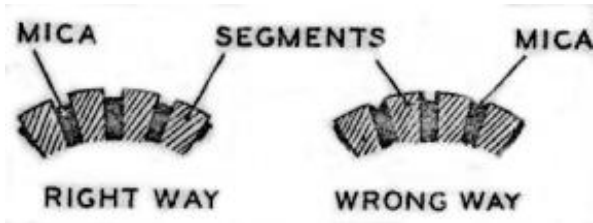

Fig. 61. Method of undercutting mica.

B (6) Dynamo – Field Coil

(a) Test the field coil by connecting it in series with a six volt battery and a six volt, three watt bulb. If the field coil is satisfactory, the bulb will light up, but its brilliance will be somewhat less than when connected direct to the battery. Failure of the bulb to light indicates an open circuit in the field winding, while if the bulb lights up with full brilliance, the field coil is probably either shortened or earthed to the pole shoe or dynamo yoke. If a shoe expander and a wheel operated screwdriver are available, it is possible to

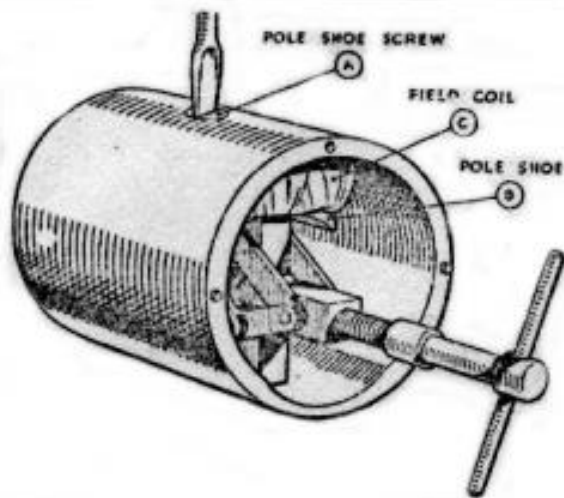

Fig. 62. Pole shoe and field coil assembly.

replace the field coil. A pole shoe expander is necessary to ensure there will not be any airgap between the pole shoe and the inner face of the yoke.

(b) Replace the field coils as follows:-

(c) Unscrew the pole shoe retaining screw (A, Fig. 62) by means of the wheel operated screwdriver.

(d) Draw the pole shoe (B) and field coil (C) out of the yoke and lift off the coil.

(e) Fit the new field coil over the pole shoe and place it in position inside the yoke. Take care to ensure that the taping of the field coil is not trapped between the pole shoe and the yoke.

(f) Locate the pole shoe and field coil by lightly tightening the fixing screw. Insert the pole shoe expander, open it to its fullest extent and tighten the screw. Remove the expander and give the screw a final tightening with the wheel operated screwdriver. Caulk the screw to lock it in position.

Dynamo - Armature

The testing of the armature winding requires the use of a volt-drop test or a growler. If these are not available, the armature should be checked by substitution. No attempt should be made to machine the armature core or to true a distorted armature shaft.

B (8) Dynamo – Bearings.

A ball bearing is fitted at the driving end and a plain porous bronze bearing bush at the commutator end.

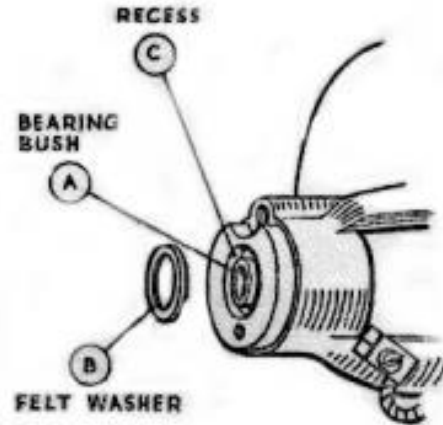

Fig. 63. Commutator end bracket with bearing bush.

Bearings which are worn to such an extent that they will allow approximately .015" total side movement of the armature shaft must be replaced. To replace the bearing bush at the commutator end, proceed as follows:-

(a) Press the bearing bush (A, Fig. 63) out of the commutator end bracket and remove the felt ring (B).

(b) Press the new bearing bush into the end bracket using a shouldered mandrel of the same diameter as the shaft which is to fit in the bearing. Note: Before fitting the new bearing bush it should

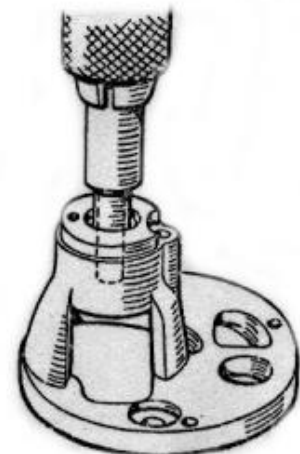

Fig. 64 Fitting bearing bush using a shouldered mandrel.

Be allowed to stand for 24 hours immersed for about 7/8ths of its length in thin engine oil. The

bush should be pressed in until it is flush with the face of the end bracket. Fit the felt ring in the space between the bearing and the wall of the bearing housing.

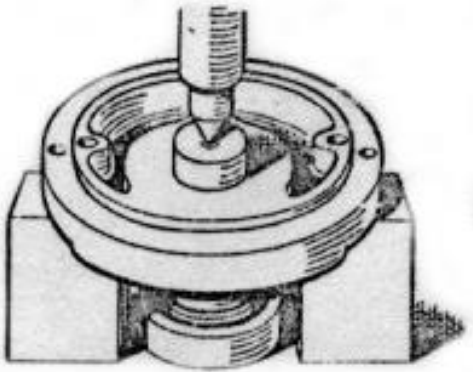

Fig. 65. Removing the ballrace.

The ball bearing (W, Fig. 59) at the driving end is replaced as follows:-

- (a) Take out the two screws (U) and the long threaded bolt (A) securing the bearing retaining plate (V) and remove the plate.
- (b) Press the bearing out of the end bracket using a metal punch locating on the inner journal of the bearing.
- (c) Wipe out the bearing housing and pack the new bearing with H.M.P. grease.
- (d) Position the bearing in its housing and press it squarely home, applying pressure on the outer journal of the bearing.

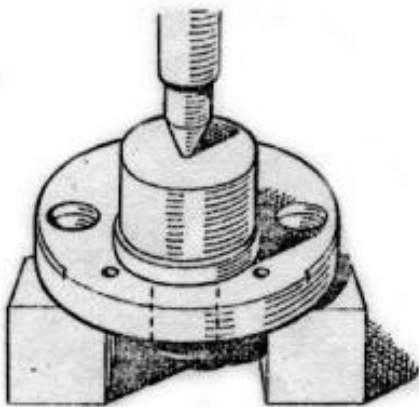

Fig. 66. Fitting Ballrace.

B (9) Dynamo – Re-assembly

In the main, the re-assembly of the dynamo is a reversal of the operations described in paragraph B (3), page 39, bearing in mind the following points:-

- (a) The field coil lead fitted with the short length of yellow tubing must be secured together with eyelet of the negative brush to the commutator end bracket by means of the screw provided.
- (b) The lead coloured white from the terminal on the positive brush box must be connected to terminal "D" on the moulded end cap.

B (10) Cut-out and Regulator Unit, Type MCR1

This unit houses the dynamo voltage regulator unit and the cut-out. Both units are accurately set and the cover should be removed for cleaning and adjustment only in the event of trouble with the charging circuit being experienced.

B (11) Regulator – Testing in position.

(a) Before checking the regulator make sure that the wiring between the regulator and the battery is in order. To do this, disconnect the wire from the "A" terminal of the regulator unit and connect

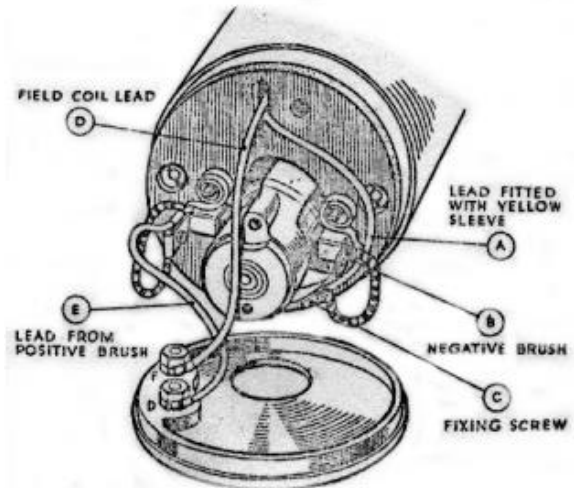

Fig. 67. Internal connections of dynamo.

The lead from the positive terminal of a voltmeter to the end of the wire. Connect the negative voltmeter lead to an earthing point on the engine. If a voltmeter reading is given, the wire is in good order and the regulator should be examined. If there is no reading examine the wiring for broken cables or bad connections.

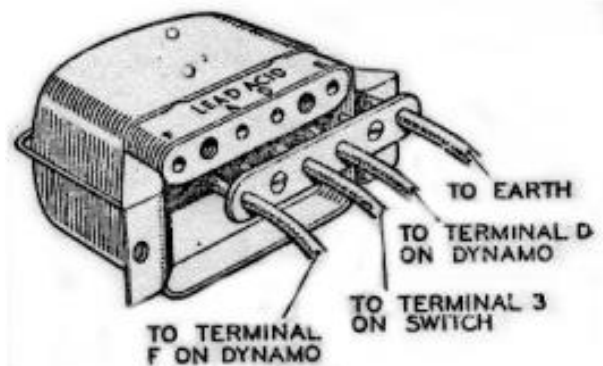

Fig. 68. Connections to the cut-out and regulator unit.

(b) Remove the cable from the terminal on the regulator marked "A". Connect the positive terminal of the voltmeter to the "D" terminal on the regulator and connect the other lead of the voltmeter to an earthing point on the engine

(c) Start the engine and slowly increase the speed until the voltmeter needle "flicks" and then steadies; this should occur at a voltmeter reading between the limits given for the particular temperature of the regulator.

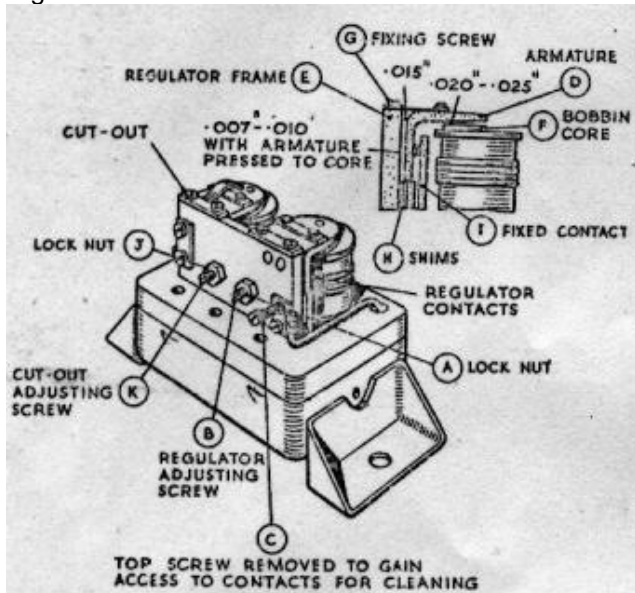

Fig. 69. Regulator adjustment and setting.

Atmospheric Temperature	Regulator Setting
30°F	7.9-8.3 volts
60°F	7.8-8.2 volts
90°F	7.7-8.1 volts

If the voltage at which the reading becomes steady is outside these limits, the regulator must be adjusted. Shut off the engine, release the locknut (A, Fig. 69) on the regulator adjusting screw (B) and turn the screw in a clockwise direction to raise the setting, or in an anti-clockwise direction to lower the setting. Turn the screw a fraction of a turn at a time and then tighten the locknut. When adjusting, do not run the engine up to more than half-throttle, as while the dynamo is an open circuit, it will build up to a high voltage if run at a high speed and so a false voltmeter reading would be obtained.

B (12) Regulator – Cleaning the Contacts.

After long periods of service it may be found necessary to clean the vibrating contacts of the regulator. These are accessible if the top screw (C) securing the fixed contact is removed and the bottom screw slackened to permit the fixed contact to be swung outwards. The contacts (D) can then be polished with a fine emery cloth.

B (13) Regulator – Mechanical Setting

The moving contact of the regulator is accurately set and should not be removed. If, however, it does become necessary to reset the contacts, proceed as follows:-

Insert a .015" feeler gauge between the back of the armature (D, Fig. 69) and the regulator frame (E). Insert a .020" - .025" feeler gauge between the top of the bobbin core (F) and the underside of the

moveable armature (D). (Not under the stop rivet). Press the armature back against the armature frame and down on to the top of the bobbin core with the feelers in position and lock the armature in position by tightening the two fixing screws (G). Adjust the gap between the regulator contacts when the armature is pressed down on the bobbin to between .007" and .010". This is done by either inserting or removing shims (H) at the back of the fixed contact (I). Finally check and if necessary reset the electrical adjustment of the regulator.

B (14) Cut-out

(a) If the regulator setting is within the correct limits, but the battery is still not receiving current from the dynamo, the cut-out may be out of adjustment or there may be an open circuit in the wiring of the cut-out and regulator unit.

(b) Remove the voltmeter lead from the "D" terminal of the regulator unit and connect it to terminal "A", the other lead from the voltmeter must still be connected to an earthing point. Run the engine as before: the reading on the voltmeter should be the same as that obtained when the

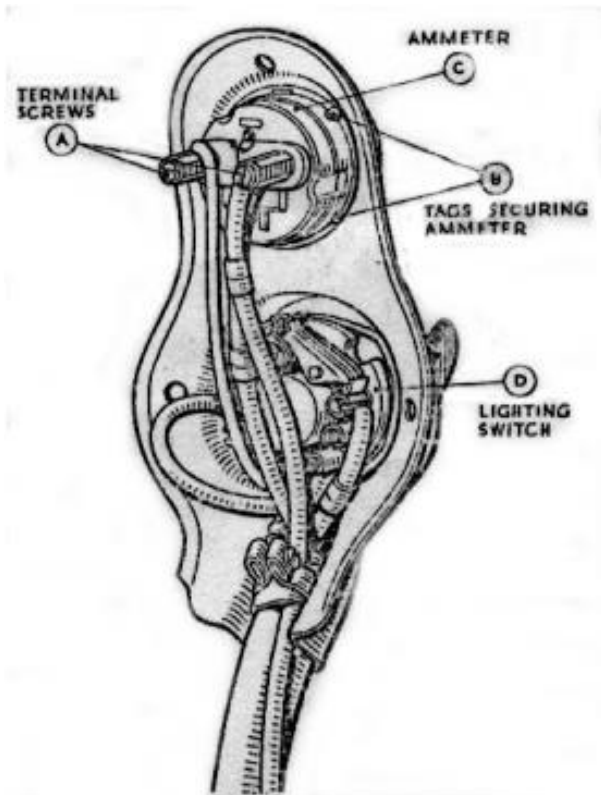

Fig. 70 Panel containing lighting switch and ammeter, removed from headlamp. For details of panel on DU42 headlamp fitted to later models see Section C (6), page 46.

Voltmeter was connected to terminal "D". If there is no reading, the cut-out may be out of adjustment and the contacts are not closing.

(c) To check the voltage at which the cut-out operates, with the engine still running, the voltmeter should be connected between the "D" terminal and earth. Slacken the locknut (J, Fig. 69) on the cut-out adjustment screw (K) and turn the screw in an anti-clockwise direction until the cut-out contacts are seen to close. Check the voltage at which the cut-out operates and if necessary adjust by turning the screw in a clockwise direction to raise the setting or anti-clockwise direction to lower it. Set the cut-out so that the contacts close at 6.2-6.6 volts. Tighten the locknut after making the adjustment.

B (15) Ammeter, Type CZ27.

NOTE. On later models no ammeter is fitted (see paragraph C6).

Ammeter – Testing in position.

(a) Take out the three screws securing the panel on the back of the headlamp and lift the panel out of the headlamp. With the engine stationary, check the voltage between each terminal of the ammeter and earth. Both readings should be the same. If there is a reading at terminal "B" but not at terminal "A", there is a broken connection in the ammeter and a replacement must be fitted.

Ammeter – Removal and Replacement.

(b) Unscrew the ammeter terminal screws (A, Fig. 70) and lift out the cable ends. Bend back the four metal tags (B) securing the ammeter and remove it from the panel. The procedure must be reversed when fitting the replacement ammeter.

B (16) Battery, Type PUW7E.

When examining a battery, do not hold naked lights near the vents as there is a danger of igniting the gas coming from the plates. Remove the vent plugs and see that the ventilating holes in each are quite clear. A clogged vent plug will cause the pressure in the cell to increase, due to gases given off during charging and this may cause damage. Make sure that the rubber washer is fitted under each vent plug, otherwise the electrolyte may leak.

Battery – Topping-up.

(a) Once a month remove the battery lid, unscrew the filler caps and pour a small quantity of distilled water into each of the cells to bring the electrolyte level with tops of the separators. Electrolyte must not be added to the battery unless some is accidentally spilled. Should this happen, the loss must be made good with electrolyte diluted to the same specific

gravity as that in the cells. This should be measured by means of a hydrometer.

Checking Battery Condition.

(b) The state of charge of the battery should be checked by taking hydrometer readings of the specific gravity of the electrolyte in the cells. The specific gravity readings and their indications are as follows:-

1.280-1.300 Battery fully charged.

About 1.210 Battery about half discharged.

Below 1.150 Battery fully discharged.

These figures are given assuming the temperature of the acid is about 60°F.

Each reading should be approximately the same. If one cell gives a reading very different from the rest it may be that the electrolyte has been spilled or has leaked from this particular cell or there may be a short circuit between the plates. This will necessitate a replacement battery being fitted. Wipe the top of the battery to remove all dirt or water.

NOTE. Do not leave the battery in a discharged condition. If a motor cycle is to be out of use, the battery must first be fully charged, and afterwards given a refreshing charge about every two weeks.

Earthing Connections.

(c) check that the lead from the negative terminal is securely connected to the cycle frame or other suitable earth.

Charging.

(d) If the previous tests indicate that the battery is merely discharged, and if the electrolyte level is correct, the battery must be recharged from an external supply. Charge the battery with a constant current of 1.2 amperes until the specific gravity of the electrolyte in the cells remain constant over a period of 1-2 hours.

If the battery does not respond to a freshening charge it must be put through what is known as a "cycle". First charge as described above for a period of 10 hours, and then discharge it at the rate of 1.2 amperes down to a terminal voltage of approximately 5.4. The time taken to discharge should be 7-8 hours. If the battery discharged in a shorter time, repeat the charging and discharging cycle. If the efficiency of the battery is not improved by this process there is probably an internal fault and the battery should be replaced.

LIGHTING AND ACCESSORIES (Section C)

C (1) Headlamp, Type DU42

The main bulb should be 6 volt 24 watt. S.B.C. double contact type. The pilot bulb should be 6 volt 24 watt. S.B.C. centre contact type.

Removing Lamp Front and Reflector.

(a) To remove the lamp front and reflector press

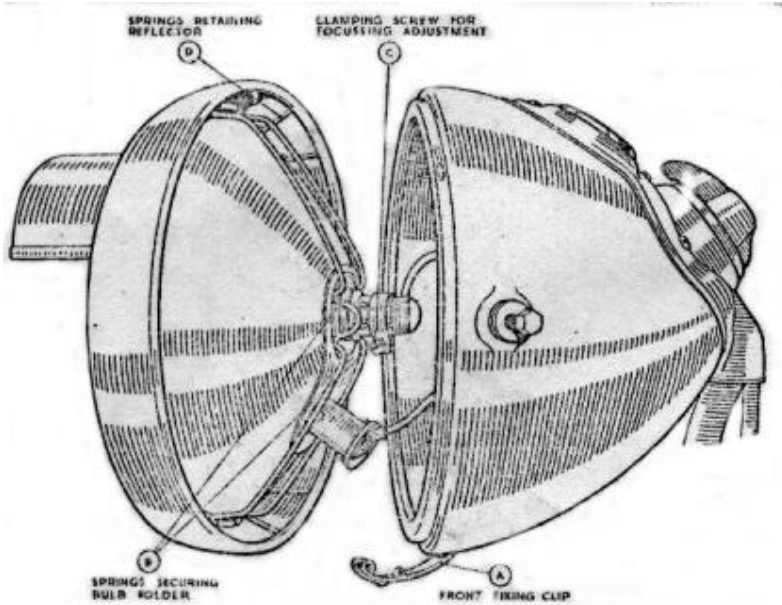

Fig. 71 Headlamp – Reflector partially removed.

back the fixing clip (A, Fig. 71) at the bottom of the lamp. When replacing the front locate the top of the rim first, then press on at the bottom and secure by means of the fixing clip.

To remove bulb holder, press back the securing springs (B).

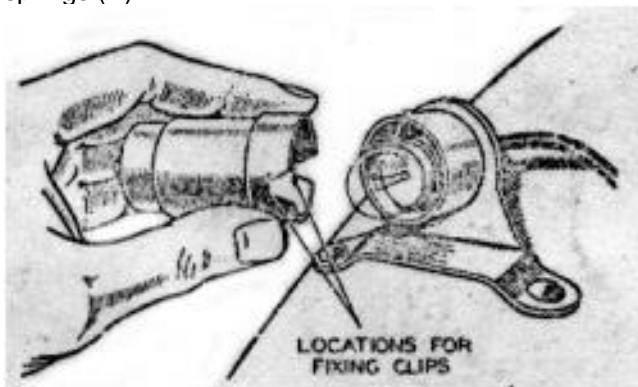

Fig. 72

Setting and Focussing

(b) The lamp must be set to ensure that the beam is projected below the horizontal.

To obtain the best driving light the bulb should be correctly focussed in the reflector. The mask fitted to the headlamp is calibrated on the basis that a parallel beam is projected from the reflector; this achieved by

focussing with the mask removed, until the smallest circle of light is obtained. Adjust by slackening the screw in the clamping band and sliding the bulb holder backwards or forwards.

Tighten the screw after making the adjustment.

The reflector can be withdrawn from the lamp front when the spring clips are sprung from their locations inside the front rim.

Cleaning

(c) Care must be taken when handling the reflector to prevent it from becoming finger-marked. It can, however, be cleaned by polishing with a clean chamois leather. Metal polishes must not be used.

NOTE: The second filament of the main bulb is for use as a spare in an emergency. To bring it into service, remove the bulb, turn it through 180° and refit. Replace the bulb at the first opportunity.

C (2) Tail Lamp, Type L-WD-MCT1

The bulb should be 6 volt, 3 watt. S.B.C. centre contact.

To remove the cover carrying the red glass, twist and pull away from base.

When replacing, position the locations in the cover over the spring and push home.

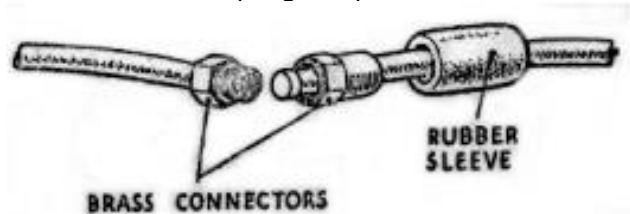

Fig. 73. Battery connector.

C (3) Cables.

Before making any alterations to the wiring or removing the switch from the headlamp, disconnect the positive lead at the battery to avoid the danger of short circuits. The lead, about one foot long, from the positive battery terminal is connected to the lead from the switch by means of a brass connector, shown in Fig. 73. The connector is insulated by a rubber sleeve, which must be pushed back to allow the connector to be unscrewed. Do not allow the brass connector to touch any metal part of the engine, as this will short circuit the battery. When connecting up again, pull the rubber sleeve over the connector.

C (4) Lighting Switch, Type RS39.

All leads to the headlamp are taken direct to the switch which together with the ammeter is incorporated in a small panel (see Fig. 70). The

panel can be removed when the three fixing screws are withdrawn. The ends of all the cables are identified by means of coloured sleeveings. The colour scheme and the diagram of connections are shown in the wiring diagram. When making connections to the switch, bare the end of the cable for about 3/8", twist the wire strands together and turn back about 1/8" so as to form a small ball. Remove the grub screw from the appropriate terminal and insert the wire so that the ball fits in the terminal post. Now replace and tighten the grub screw; this will compress the ball to make a good electrical connection.

C (5) Horn, Type HF1235

Electric horns are adjusted to give their best performance before leaving the works and will give a long period of service without any attention. If the horn becomes uncertain in action or does not vibrate, it has not necessarily broken down. The trouble may be due to a discharged battery or a loose connection or short circuit in the wiring of the horn. The performance of the horn may be upset by the fixing bolt working loose, or by the vibration of some part adjacent to the horn. To check this remove the horn from its mounting, hold it firmly in the hand by its bracket and press the push. If the note is still unsatisfactory, the horn may require adjustment.

Method of Adjustment

The adjustment of a horn takes up wear of vibrating parts which if not corrected, results in loss of power or roughness of tone. The adjustment is made by turning the adjustment screw, usually in a clockwise direction. The underside of the screw is serrated, and the screw must not be turned for more than two or three

notches before retesting. If the adjustment screw is turned too far in a clockwise direction, a point will occur at which the armature pulls in but does not separate the contacts.

When testing do not continue to operate the push if the horn does not sound. If when the push is operated, the horn does not take any current (indicated by an ammeter connected in series with the horn), it is possible that the horn has been adjusted so that its contact breaker is permanently open.

After adjusting, note the current consumption. A horn may give a good note, yet be out of adjustment and taking an excessive current. When adjusting, do not attempt to unscrew the nut securing the tone disc or any other screw in the horn.

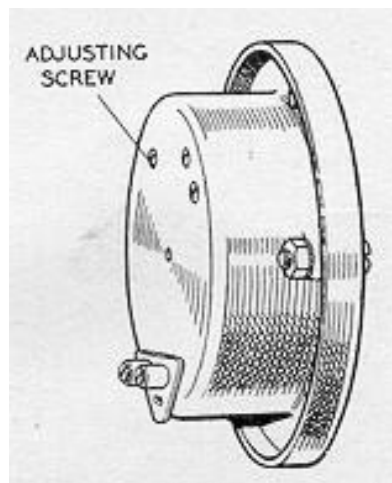

Fig. 71. Horn showing adjusting screw.

The current, when the horn is adjusted to give its best performance must not exceed 4-5 amperes.

C (6) Headlamp, Type DU 42. Fitted to later models.

The headlamp incorporates the main bulb (6 volt 24 watt S.B.C. double contact, double filament type) and the pilot bulb (6 volt 3 watt S.B.C. centre contact type).

It differs from the type described in Section C (1), page 44, in that the ammeter is omitted and the main lighting switch is removed from the lamp and is mounted on a separate bracket. The lamp is fitted with a push operated switch by means of which the rider can change from the main bulb to the pilot bulb or vice versa.

The method of removing the front and reflector and of setting the focussing remains as described in Section C (1), page 44.

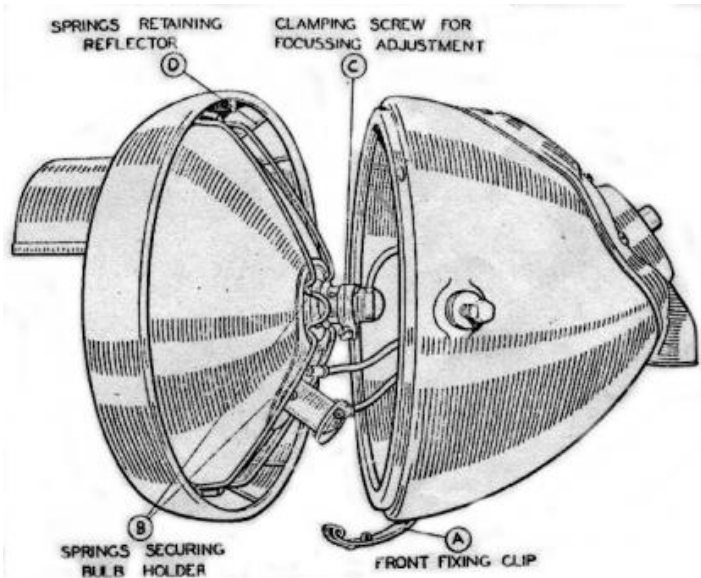

Fig. 75. Headlamp, type DU42 with reflector partially removed.

Change-over Switch

A single lead connects the main lighting switch to the change-over switch and two cables connect the change-over switch to the main and pilot bulb holders. To remove the switch proceed as follows:

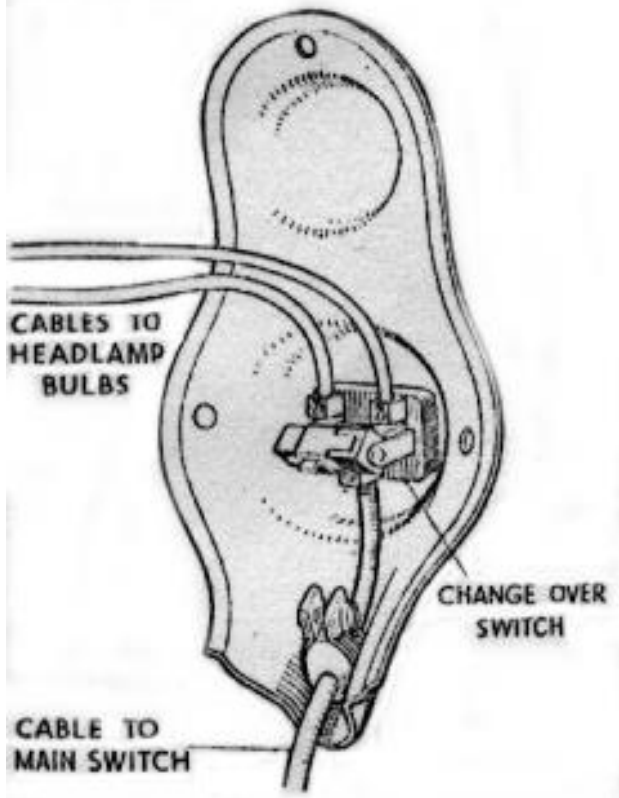

Fig. 76. Panel containing change-over switch, removed from headlamp.

Take out the three screws securing the panel plate fitted at the back of the lamp and withdraw the panel (Fig. 76). Slacken the three screws in the switch terminals and lift out the cables. Hold the switch body, unscrew the bezel ring on the outside of the switch and withdraw the switch, connect the cable fitted with the blue sleeving to the single terminal on the one side of the switch plate and connect the two cables from the bulb holders to the other two terminals.

Main Lighting Switch

The switch has four positions as follows:-

TEST

OFF

T. Tail lamp on.

H. Headlamp and tail lamp on.

The "Test" position is provided to enable the rider to check that the dynamo is functioning correctly. In this position the tail lamp is connected directly to the "D" terminal on the regulator unit. To check the dynamo performance, start the engine and allow it to run at a fairly fast idling speed and move the switch to the "Test" position. If the dynamo is operating correctly the tail lamp should light up brightly. As a further check of the charging system, switch on the headlamp with the engine stopped and after about two minutes, start the engine and partly open the throttle. An indication that the charging system is satisfactory is given if the brightness of the lamp increases.

The switch terminals are accessible when the moulded cover, which is secured by three nuts, is moved back along the cables.

TOOL KIT SUPPLIED WITH THE MACHINE

B.S.A. Part No.	Description
33-9030	Tool Bag
29-9251	Magneto Spanner
66-9039	Sparking Plug Spanner
15-832	Box Spanner
29-9254	Hub Bearing Adjusting Spanner
EB259	B.S.A. Double Ended Spanner
66-9036	Cylinder Base Nut Spanner
29-9253	Spanner Tommy Bar
66-9068	Detachable Wheel Spanner
28-4265	Oil Gun (Tecalemit)
15-8945	Carburetter Spanner
65-9132	Tappet Adjusting Spanner
65-9133	Tappet Adjusting Spanner
66-9067	Hub Spindle Nut Spanner
66-9052	Front Hub Bearing Adjusting Spanner
66-9130	Tappet Feelers
EB262	Adjustable Spanner
EB263	Pliers
EB261	Screwdriver
66-9038	Screwdriver Attachment
66-9042	Wheel Alignment Gauge
65-9144	Magdyno Spanner

ADDITIONAL EQUIPMENT

B.S.A. Part No.	Number per set	Description
66-9148	1	Wesco Type 200 Oil Can
66-9154	1	4oz roll Insulating Tape (½ " wide).
66-9168	2	Tyre Levers (spoon type)